

PATRIOT

*High Quality Low Voltage
Vehicular Swing Gate Operator
Solar or AC Charged*

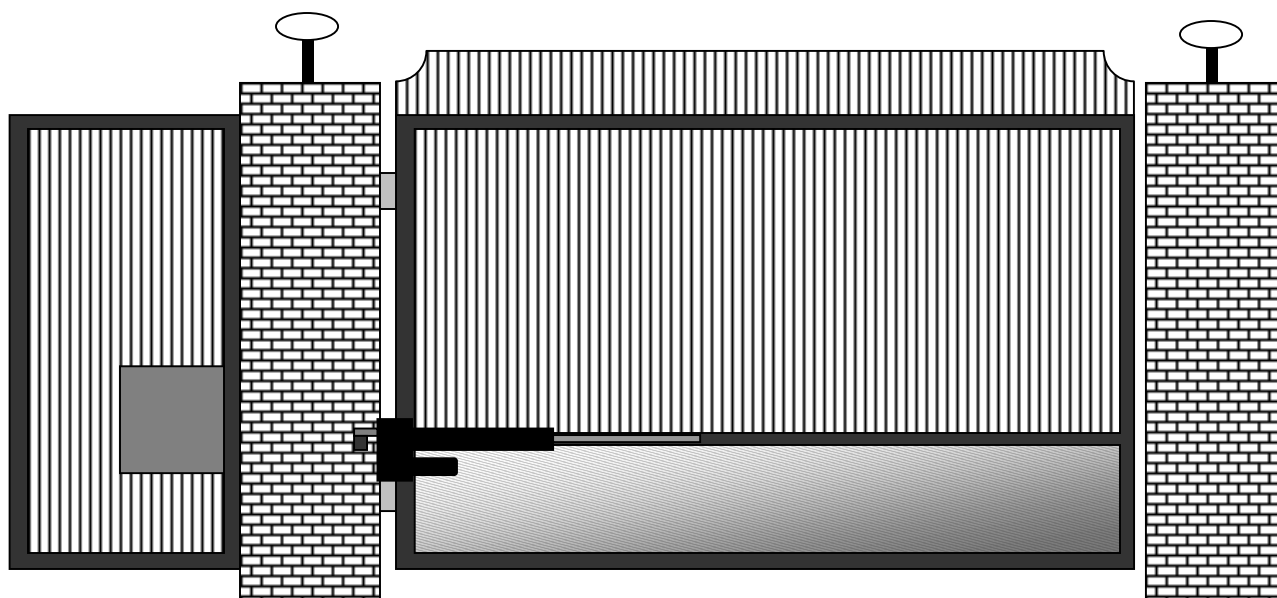

PATRIOT I Single Swing Gate Operator

PATRIOT II Dual Swing Gate Operator

Installation/Owners Manual



PROUDLY MADE IN THE USA

www.usautomatic.com



INTRODUCTION

This operator is intended to be installed on vehicular Class I or Class II gates as defined by UL 325. Maximum gate load not to exceed 650 pounds.

PLEASE READ THIS ENTIRE MANUAL CAREFULLY PRIOR TO INSTALLATION. In doing so, along with performance of the installation in step-by-step order, you will achieve optimal results. We strongly recommend that all installation and service personnel pay particularly close attention to the safety systems section of this manual and UL 325. In addition to the current sense feature that is provided, other safety devices are necessary to make each particular installation as safe as possible to reduce the risk of personal injury and/or property damage. A trained and authorized service technician or the factory should be consulted for assistance.

Cautions - Very Important

- ⇒ Do not attempt to enter the gate area while the gate is moving. Wait until the gate comes to a complete stop.
- ⇒ Operate the gate only when it is fully visible, free of persons or obstructions, and properly adjusted.
- ⇒ Do not allow children to play in the area of the gate. Do not allow anyone to ride on the gate.
- ⇒ Do not allow children to play with the remote control or any other activation device.
- ⇒ Do not attempt to "beat the gate" while the gate is opening or closing. This is extremely dangerous.
- ⇒ Test the current sense feature and all safety devices regularly to insure correct operation.
- ⇒ Study the entire Safety Section (page 17-20), paying particularly close attention to the Entrapment zones on page 18-20 and be aware of these areas not only during use but also during any adjustments to the unit.
- ⇒ The USAutomatic battery charger is designed to operate with 12 vdc deep cycle batteries rated at 60-amp hour minimum. Gel type is recommended.
- ⇒ **Modifying the charger AC supply cord will void the charger warranty.**

Other Safety Standards

- ⇒ All control stations should be located at least 6 feet from any moving part of the gate or operator.
- ⇒ Do not ever install any control device where a user will be tempted to reach through the gate or fence to activate a gate.

© USAutomatic, Inc., 2003 rev ZI
All rights reserved. No part of this may be reproduced by any means
without the expressed written consent of the publisher.

Table Of Contents

	<u>Page</u>
Introduction.....	1
Table of Contents.....	2
General Requirements/Gate Qualifications & Applications	3
Importance of a Properly Designed Gate	4
Mounting Site Review	4
Parts Included List	5
Hinge Mount Tube Installation/Pull to Open/Push to Open	6
Hinge Mount Tube Installation/Vertical Height	7
Preparation of Actuator for Installation.....	8
Actuator Installation	8,9
Mounting the Gate Bracket/Control Box/Actuator Cable Splicing	9
Master/Slave Dual Gate Wiring/Push to Open Applications	10
Charging Source Installation/Solar or AC.....	11
Installing Safety Placards/Secondary Entrapment Siren	11
Final Adjustments Current Sense Adjust	12
Limit Switches/Limit Assembly Operation.....	13
Circuit Board & Terminal Description.....	14
Function of Programming Switch Settings DS1	15
Function of Programming Switch Settings DS2	16
Emergency Manual Release	16
Safety Section	17-20
Periodic Service	21
Troubleshooting Introduction	21
Troubleshooting Guide	21-26
Accessory Wiring Diagrams.....	27-31
Magnetic Wire Sensing Loops	32-34
Warranty Statement / Mail in Registration.....	Back Cover

GENERAL REQUIREMENTS

General hand/tools such as combination wrenches, tape measure, level, clamps, etc. are required. Your particular installation may require a drill or other hardware not provided. Welding by a qualified welder is the recommended method of securing the linear actuator mounts to the gate and hinge post. Bolt on brackets is an option, but they must be very securely attached (i.e. carriage bolts with lock nuts and washers). Lag type bolts are not recommended. Loose or unstable operator mounts will result in improper operation.

BATTERY REQUIRED FOR OPERATION (NOT INCLUDED).

We recommend a 12-volt deep cycle gel battery rated at a minimum of 60-amp hours. The actuator harness is equipped with ring terminals designed to connect to bolt type battery post. The USAutomatic charger is designed for this type of battery and using a smaller amp hour battery may cause damage to the charging system.

IMPORTANT CAUTIONS:

1. Do not test or operate this unit without the actuator securely attached to the gate. Serious damage to the actuator limit switch assembly may occur if attempted.
2. Do not perform any welding with the actuator cable plugged into the control board or the battery connected. Serious damage to the control board and/or battery will occur if attempted.
3. Always disconnect the battery power from the unit prior to connecting any devices.

GATE QUALIFICATIONS/APPLICATIONS

GATE LENGTH/WEIGHT

This gate operator is rated for vehicular class I or class II swing gates up to 16 feet in length and up to 650 pounds in weight as defined by UL325. If your gate exceeds either one of these limits, please consult a qualified technician or the factory for alternative solutions. (Example: Convert one 20' gate into two 10' gates and use a dual gate operator.)

Note: *The total gate opening normally cannot exceed 110 degrees.
Consult a service technician or the factory if greater opening is required.*

GATE CYCLES PER DAY

Solar charged systems should not exceed 25 complete open/close cycles per day, without additional solar panels. This actuator type opener, whether AC or Solar charged, should never be used in applications, which exceed 150 complete open/close cycles per day. Holding the gate open can decrease cycles during high cycle time periods. If more cycles are required, a high traffic gate opener should be used.

IMPORTANCE OF A PROPERLY DESIGNED GATE

As a general rule a gate, which is to be automatically operated must be stronger and smoother than one, which will be manually operated. Since the gate is a major component of the system, great care and concern must be given to the gate design.

A GATE OPERATOR CANNOT OVERCOME A POORLY DESIGNED GATE.

- A. Does the gate swing smoothly without binds or excessive resistance? Swing gates should swing level and plumb to prevent the operator from having to lift the gate open or closed. Swing gates should not require a wheel to support them. Wheels usually create drag, which will cause operator problems. A wheel is generally a sign of a weak hinge system or a weak gate frame.
- B. Is the gate frame of substantial strength without excessive weight? Will the frame withstand normal wind load conditions without sway or vibration? Will the gate close correctly without being hand-guided or lifted to close?
- C. Are the hinges suited for the number of cycles expected per day?
We recommend bearing type hinges to reduce friction drag.
- D. Will a reinforcement brace be required to attach the operator to the gate or does a suitable cross member exist in the gate design?

If any of these problems exist, they must be corrected to achieve a reliable automatic gate system.

MOUNTING SITE REVIEW

Installers should ask themselves these questions prior to installation and predetermine the solution to any problems, which may occur.

- A. Does sufficient space exist for mounting and future servicing of the operator and control box?
- B. Will the unit push the gate open to the outside or pull the gate open to the inside?
- C. How will the actuator mounts be secured at the hinge and to the gate?
- D. How will the control box be mounted securely enough to support the weight of the battery and can it be located within 8 feet to prevent splicing of the actuator cable?
- E. How will power be brought to the control box if AC charged?
- F. How and where will the solar panel mount if solar charged so that optimum sunlight is received?
- G. How will exterior control wiring, if any, be brought to the control box?
- H. Have all safety concerns been addressed? (See Safety Section Pgs. 17-20)

PARTS INCLUDED

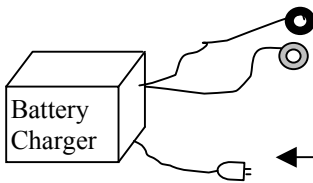
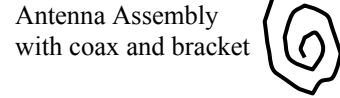
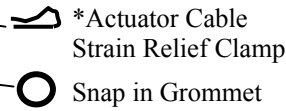
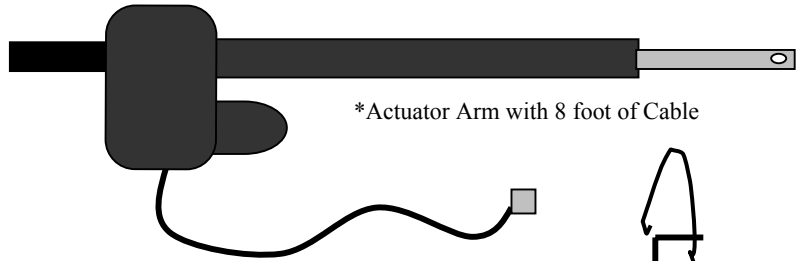
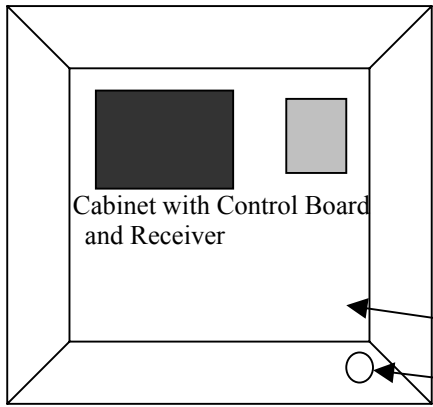

OR

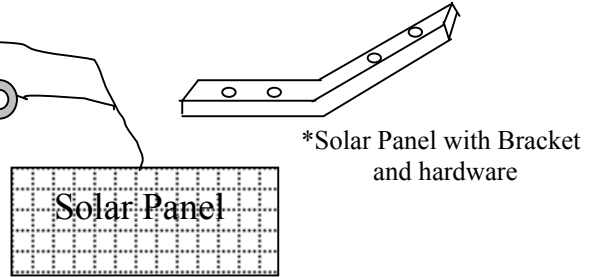

1- Transmitter

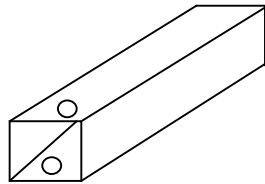

2" X 2" X 17"
*Tube

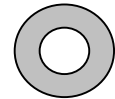
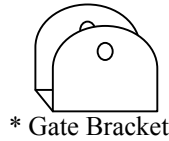

*3- 1/2" washers



* 1/2" X 4 1/2" Bolt

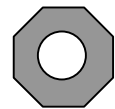

*1- 1/2" Locknuts

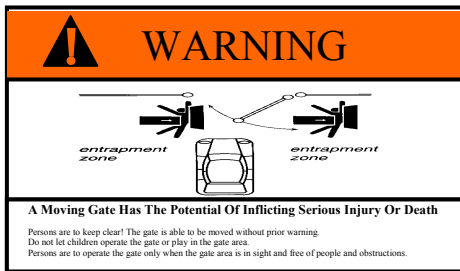

2- Placards

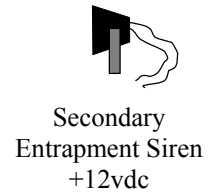
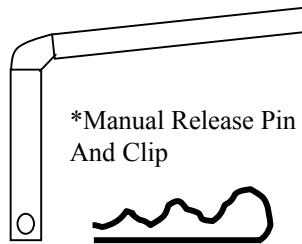

- ***For Patriot II quantity is doubled.**
- **Additionally, 40' of Master/Slave Actuator cable provided with the Patriot II**
- **Placards (Two supplied) should be visible from inside and outside of gate.**

NOTE: 12 Volt DC deep cycle battery 60-amp hour minimum required. (Not Included)

STEP 1 Hinge Mount Tube Installation (Part 1)

PULL TO OPEN / TOP VIEW (SEE BOTTOM OF PAGE FOR PUSH TO OPEN)

(Left-handed installation shown. Reverse for right-handed installation)

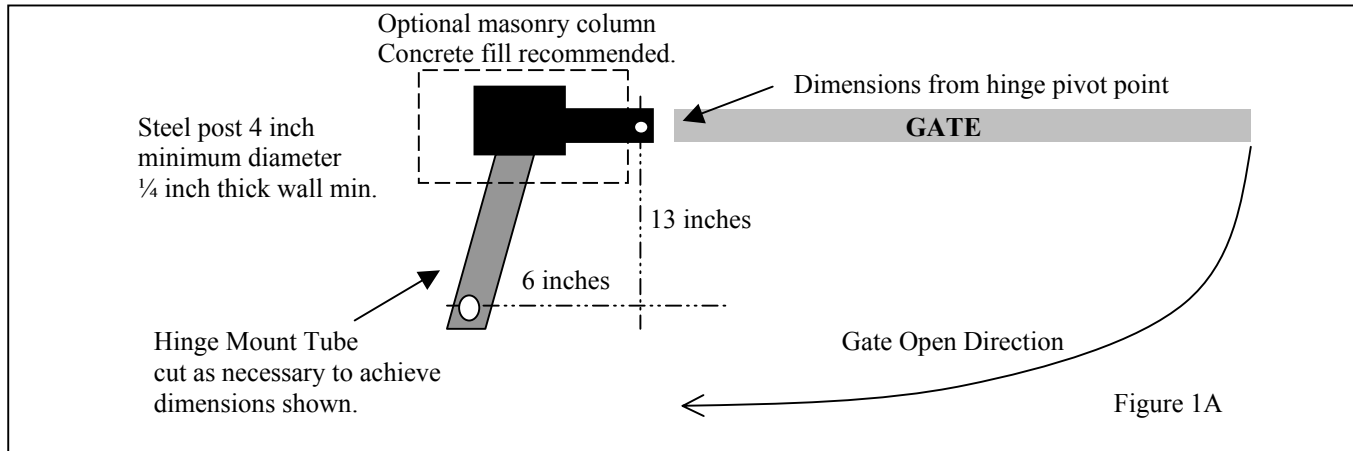

Other Typical Methods for

Pull to Open Applications

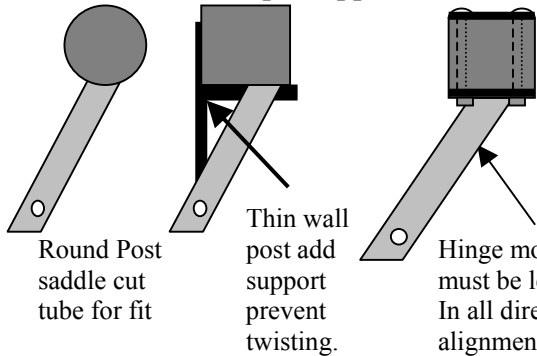

Wood post add metal plate and bolt on with 1/2 inch carriage bolt/washers/nuts.

Push to Open Applications

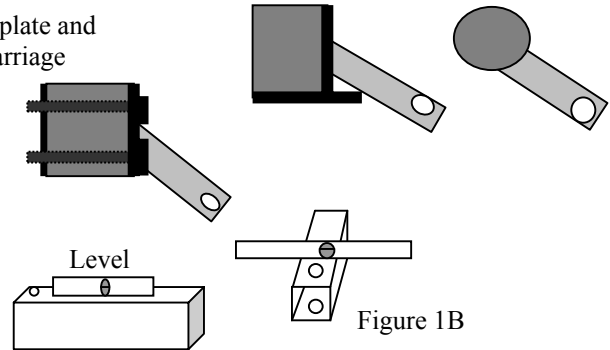

STEP 1 Hinge Mount Tube Installation (Part 2)

PUSH TO OPEN / TOP VIEW (SEE TOP OF PAGE FOR PULL TO OPEN)

(Left-handed installation shown. Reverse for right-handed installation)

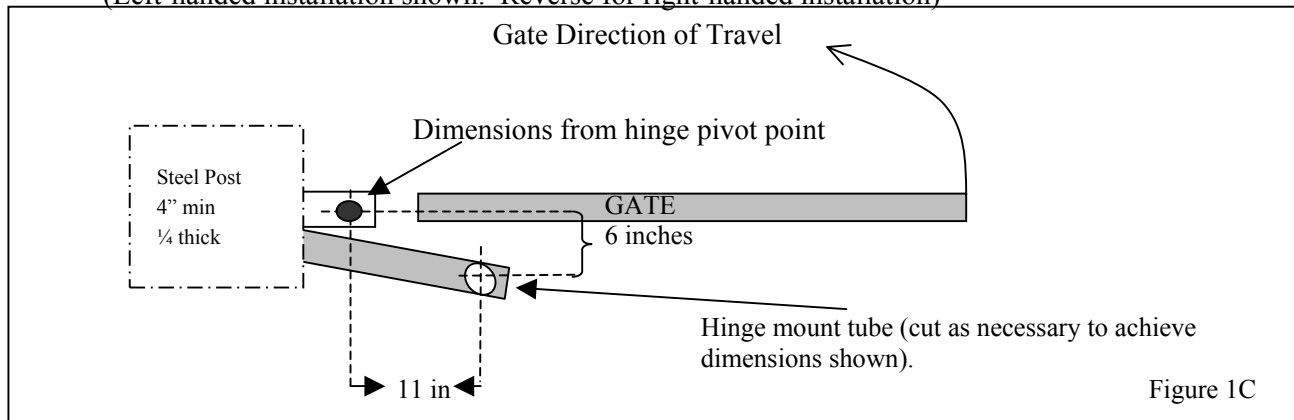

Regardless of method used, the hinge mount tube should be very secure since the entire force of the gate is directed to this mount. The post must be of adequate strength to resist twisting as well.

Conform to dimensions shown at top of page always. See page 7 to locate height of hinge mount tube on post.

Note: *USAutomatic is not responsible for failure to comply with UL325 standards, local building codes or improper installations.*

STEP 1 Hinge Mount Tube Installation (Part 3)

VERTICAL HEIGHT POSITIONING

Refer to figures 2B-2F to determine the best location for the actuator on the gate. Then use figure 2A to determine the height of the hinge mount tube and gate bracket. The middle of the gate is the ideal location for the actuator. The top or bottom of the gate frame are also possible locations.

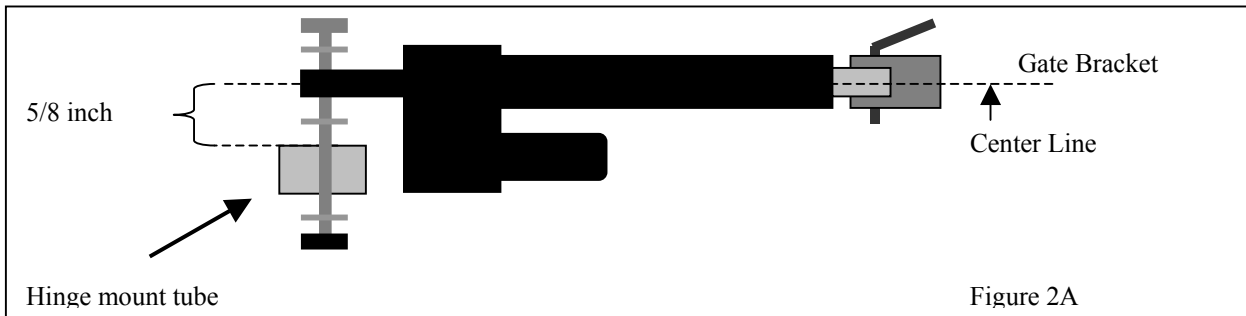

Correct Installation

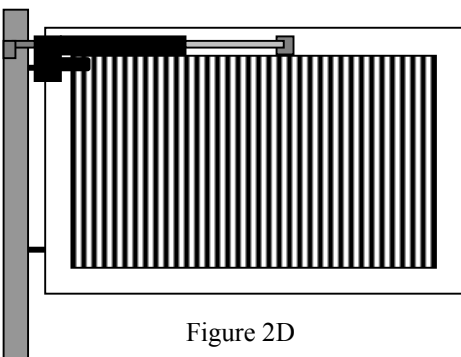
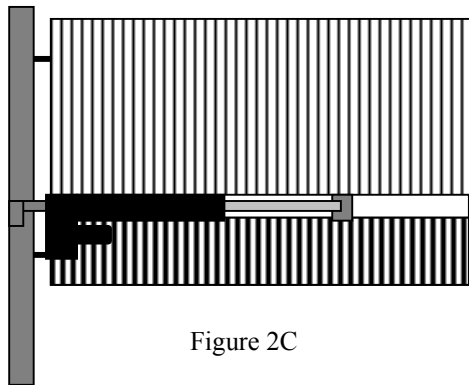
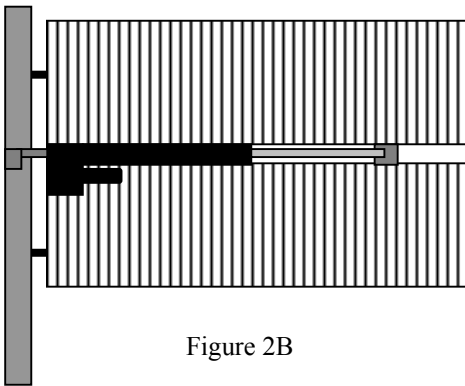

Incorrect Installation

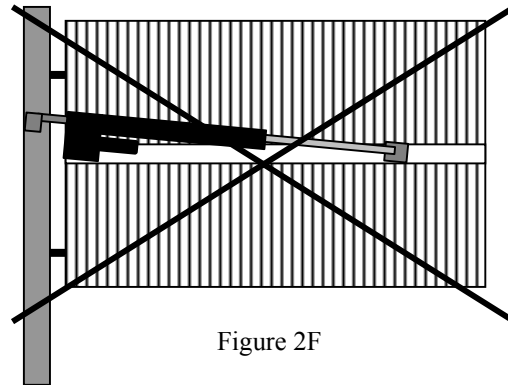
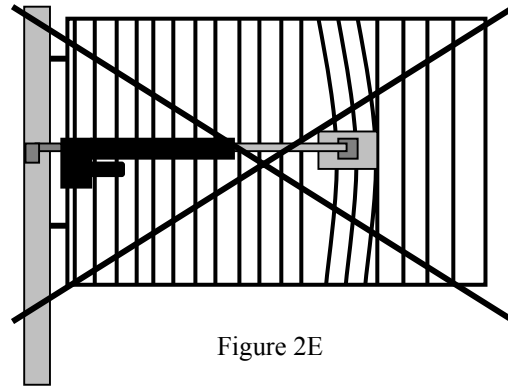

IMPORTANT:

The gate bracket must be welded in an area that can withstand the full force of the gate. Do not simply weld across a few pickets or bending of the pickets will occur. Add a cross bar if necessary or weld the bracket to the gate frame.

STEP 1 Prepare Actuator for Installation

Assemble the actuator to the gate bracket as shown in figure 3A

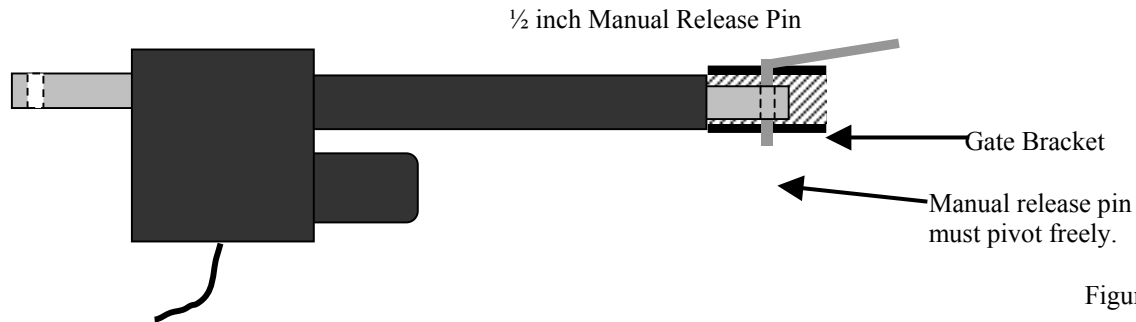

STEP 2 Actuator Installation

NOTE: *To simplify Limit switch adjustment during installation, the actuator may temporarily be mounted upside down.*

The actuator is adjusted to the fully retracted or open position from the factory. Once the actuator is connected to the hinge mount tube, swing the gate to the desired fully open position and determine location of the gate bracket.

Mount the actuator to the hinge mount tube as shown in Figure 4A.
Support the free end of the unit while mounting.

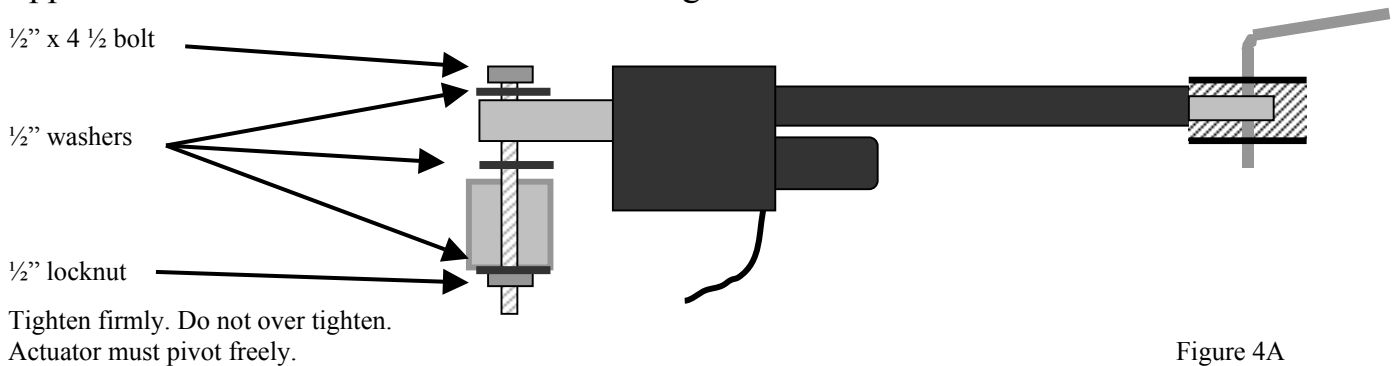

Do not permanently mount the actuator upside down. Mount only as shown in the illustrations.

Open the gate to the desired OPEN position and block in place to secure the gate and determine gate bracket weld point.

NOTE: *The total opening cannot exceed 110 degrees. Consult a service technician or the factory if greater opening is required.*

STEP 3 Mounting of Gate Bracket (PULL to Open Only)

Clamp the gate bracket to the gate at the previously determined point and weld to gate. Be sure that your gate does not move while clamping. The location of the gate will set your open position. The actuator cylinder will be level if all steps were performed accurately.

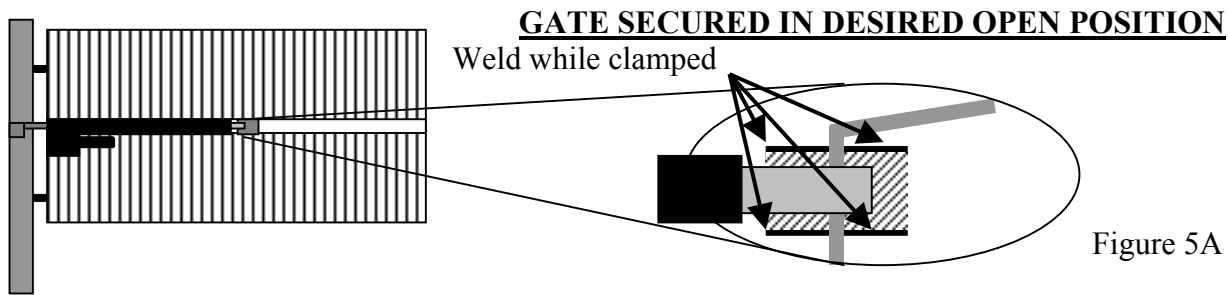

Figure 5A

STEP 4 Mounting of Gate Bracket (PUSH to Open Only)

Close the gate to the desired CLOSED position and block in place to secure the gate and determine gate bracket weld point. Clamp the gate bracket to the previously determined point and weld to gate. Be sure that your gate does not move while clamping. The location of the gate will set your closed position. The cylinder will be level if all steps were performed accurately.

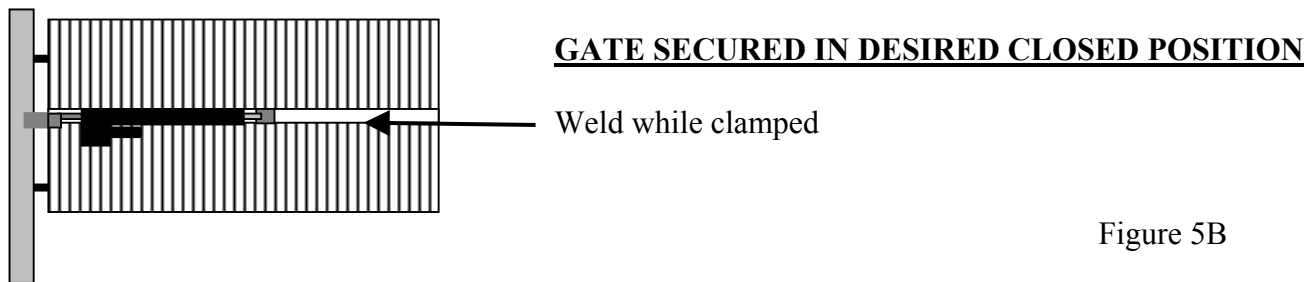

Figure 5B

STEP 5 Mounting Control Box/Actuator Cable Splicing

NOTE: *Push to open installations. See page 10 for more details.*

Correct – Install control box to fence by welding or screws. Keep in mind that the actuator cable is 8' in length (avoid splicing cable if possible) if splicing is necessary water tight splices are a must. If drilling is required remove control board and all electronic devices to avoid damage from shavings.

Incorrect – Do not mount in areas by automatic sprinklers or flood prone areas. It is important that all electronics in the control box remain dry.

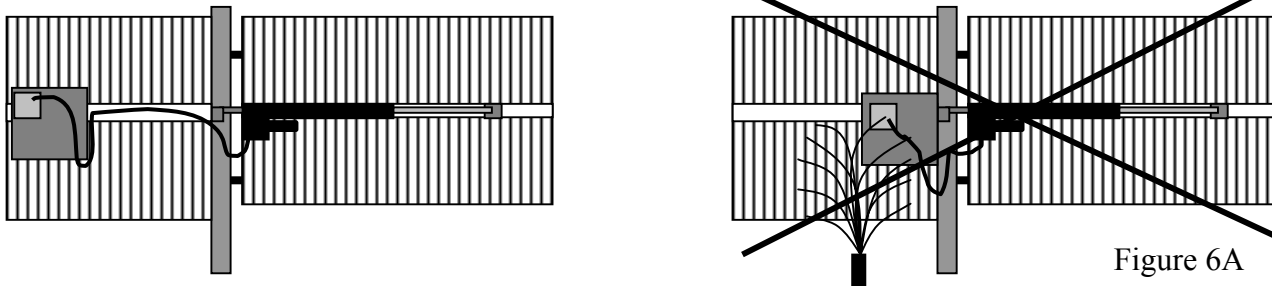
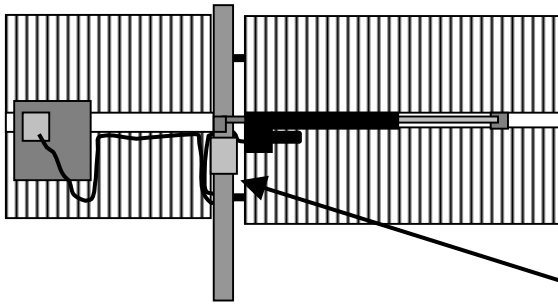

Figure 6A

After securely mounting control box install battery and all electronic components. Route actuator cable through the bottom of control box; do not connect to battery or control board at this time.

Splicing For Actuator Cable

PATRIOT I Single Gate Wiring (only if required)



If 8' actuator cable must be spliced a watertight junction box must be used to prevent moisture from splice. The wire used for the splice should be no smaller than the actuator cable wire provided. Use only approved wire nuts or crimp splices for connection. Make second splice inside control box. 5-conductor cable (2-12gauge, 3-18 gauge wires). Extension cable is sold separately.

Junction Box (Water tight)

Figure 7A

PATRIOT II Dual Gate Wiring (Splice Required for Slave Actuator)

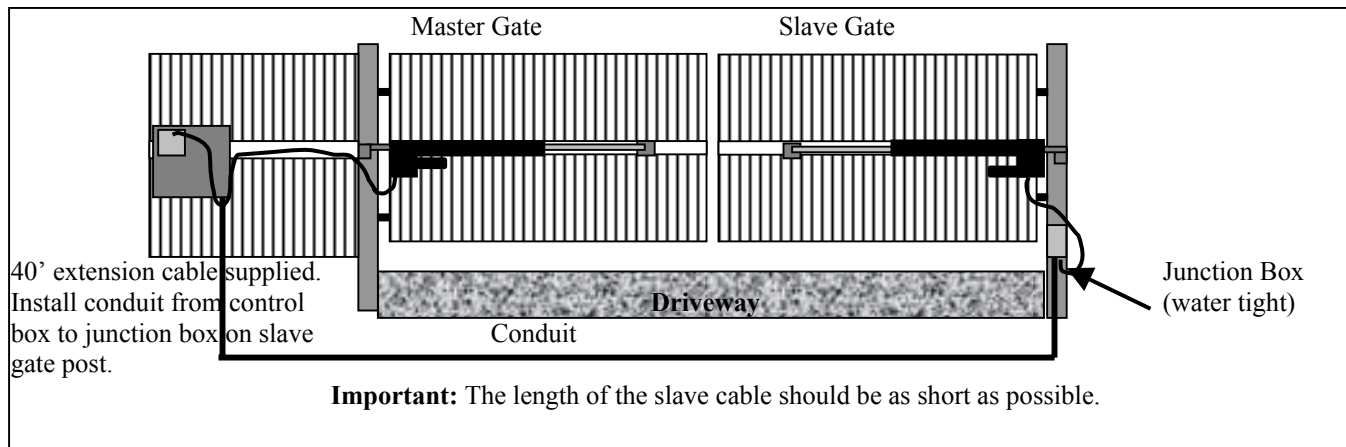

The extension cable supplied with the operator contains the same color wires as the actuator cable splice by matching the colors.

NOTE: Failure to install extension cable into watertight conduit and keep all connections dry will result in future problems.

Push to Open Cable Applications

Cable modifications are not necessary for push to open installations. The microprocessor on the circuit board will take care of all wire reversing and logic associated with this type of installation.

DS1 switch number 9 (see page 15) must be in the "ON" position.

NOTE: The only thing to remember is that when DS1 switch 9 is on the Limit lights on the circuit board will show open when closed and closed when open.

STEP 6 Installation of Charging Source

SOLAR PANEL

Locate and mount the solar panel bracket so that the panel faces southwest and maintains the preformed 45-degree angle. The standard cable is 10' in length and must feed in through the bottom of the control box. Pay attention to the distance when determining you're mounting location. Although the cable can be extended with watertight connectors, charging power is diminished. Sometimes it is necessary to locate the panel farther away to achieve optimum sunlight, but consider that optimum sunlight might not mean optimum charging if the distance is too great. Use #16 gauge wire or larger and keep length as short as possible.

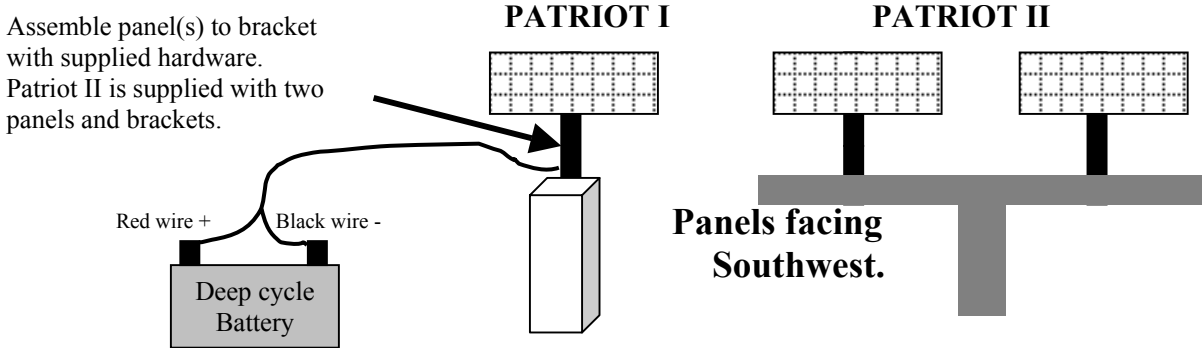

Note: *Avoid shaded areas if possible. Panels should face southwest for optimum charging. See explanation above for details.*

AC CHARGER

Locate and install the AC battery charger inside the control box. The charger requires a receptacle for 110-volt AC supply; recommended location is inside the control box. A licensed electrician per local building codes should install the receptacle. **Modifying the charger power cord will void the warranty.**

Note: *USA Automatic recommends an AC surge protector on all 110-volt installations. Especially in lightning prone areas. Do not modify the AC cord on the charger.*

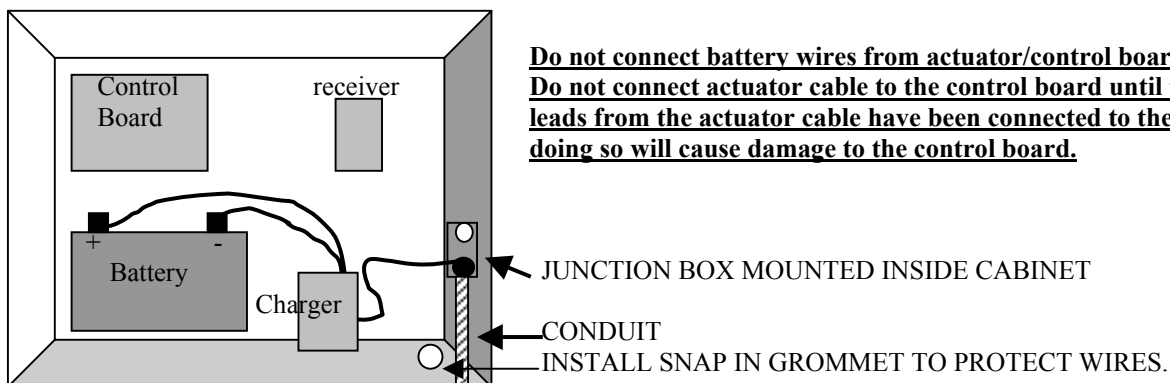

STEP 7 Installing Safety Placards

Mount safety placards on gate. Two signs are provided. Place one sign on each side of the gate where it will be highly visible to anyone on either side of the gate.

STEP 8 Installing Secondary Entrapment Siren

The secondary entrapment siren connects to the control board (see pages 12,31). This siren is very loud and will be activated anytime the current sense circuit stops the gate twice prior to reaching a fully open or close limit. The reset button on the control board (see page 12) must be pushed to turn off the siren, and reset the control board.

STEP 9 Making Final Adjustments

In order to make final adjustments, a signal device such as a radio control should be used. The control board is equipped with an “Open / Close Command” pushbutton for this purpose. The gate will open if closed or close if in the open position. A signal in mid-travel will stop the gate.

- If your unit was purchased with a radio receiver, it is important that you change the dipswitch code settings in your receiver and in all of your transmitters. Please consult a dealer for assistance.

IMPORTANT NOTES

1. Locate the actuator cable plug and be aware that you may need to disconnect it if the cylinder over travels the desired stop points. You should be able to stop the motor with the open/close command button or the reset button on the control board or a signal from your device without having to disconnect the plug, but in cases of incorrect wiring, the plug can be used as an emergency power shut-off.
2. Locate the sensitivity adjustments. Notice that there are two adjustments MASTER and SLAVE we intentionally set the sensors at a highly sensitive setting. This may need to be adjusted to achieve gate movement without tripping the sensitivity circuit and causing the gate to reverse direction. If the gate reverses direction twice and then stops the control board will need to be reset. See Current Sense Adjustment and reset button location below.
3. Study the limit switch section and instructions on adjusting the limit switches prior to battery hook up. See page 13 for details.

If you have an understanding of the sensitivity feature, how to disconnect the actuator plug in an emergency, and how to adjust the limit switches, then proceed to hook up the battery leads and connect the actuator plug to the control board. The red battery lead goes to the positive + terminal on the battery and the black lead goes to the negative - terminal on the battery.

Caution: Connect battery leads to battery before connecting actuator plug to the control board.

Current Sense / Sensitivity Adjust

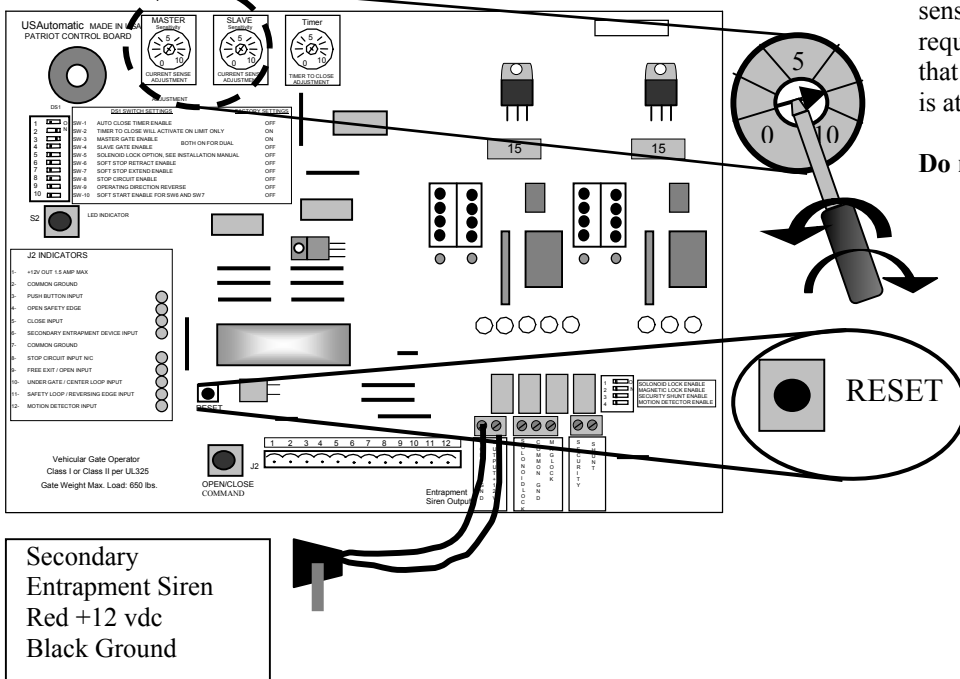

The control board has two adjustments for sensitivity MASTER and SLAVE. Dual gates will require adjustment of both, adjust sensitivity so that the gate force required to sense an obstruction is at the desired level.

Do not turn the adjustment screw past 0 or 10.

If the sensing circuit is activated twice before reaching an open or closed limit the unit will stop operating and sound the secondary entrapment siren and require a reset.

Remember if the gate reverses direction when operating without contacting an obstruction, then minimizing sensitivity (increase force) may be required. Do not increase more than necessary.

Secondary Entrapment Siren
Red +12 vdc
Black Ground

CAUTION: To reduce the risk of injury, USAutomatic strongly recommends the installation of additional safety devices such as Photo Eye Sensors and Safety Edges. Consult an authorized installing dealer or the factory for a complete explanation of options and see the Safety Section of this manual on pages 17 to 20.

LIMIT SWITCHES

The limit switch adjustments are located on the bottom of the actuator. Remove the dust plug to make adjustments. The normal settings from the factory allow for 18" of travel (approx. 70% opening). You will most likely have to adjust the extend or close limit for your installation. The adjustments are labeled "Extend" and "Retract" on the dust plug. Flat blade screwdriver is included with the operator.

If soft start / stop is going to be used turn switch 6 or 7 (see page 15) on at this time. Prior to operation the retract limit will need to be adjusted about 5 turns counter clockwise before operating.

NOTE: ALL ADJUSTMENTS SHOULD BE MADE IN THE MID TRAVEL (1/2 OPEN) POSITION. DO NOT FORCE THE ADJUSTMENT; FORCING WILL DAMAGE THE LIMIT ASSEMBLY. REMOVE THE ADJUSTMENT TOOL AFTER EACH ADJUSTMENT.

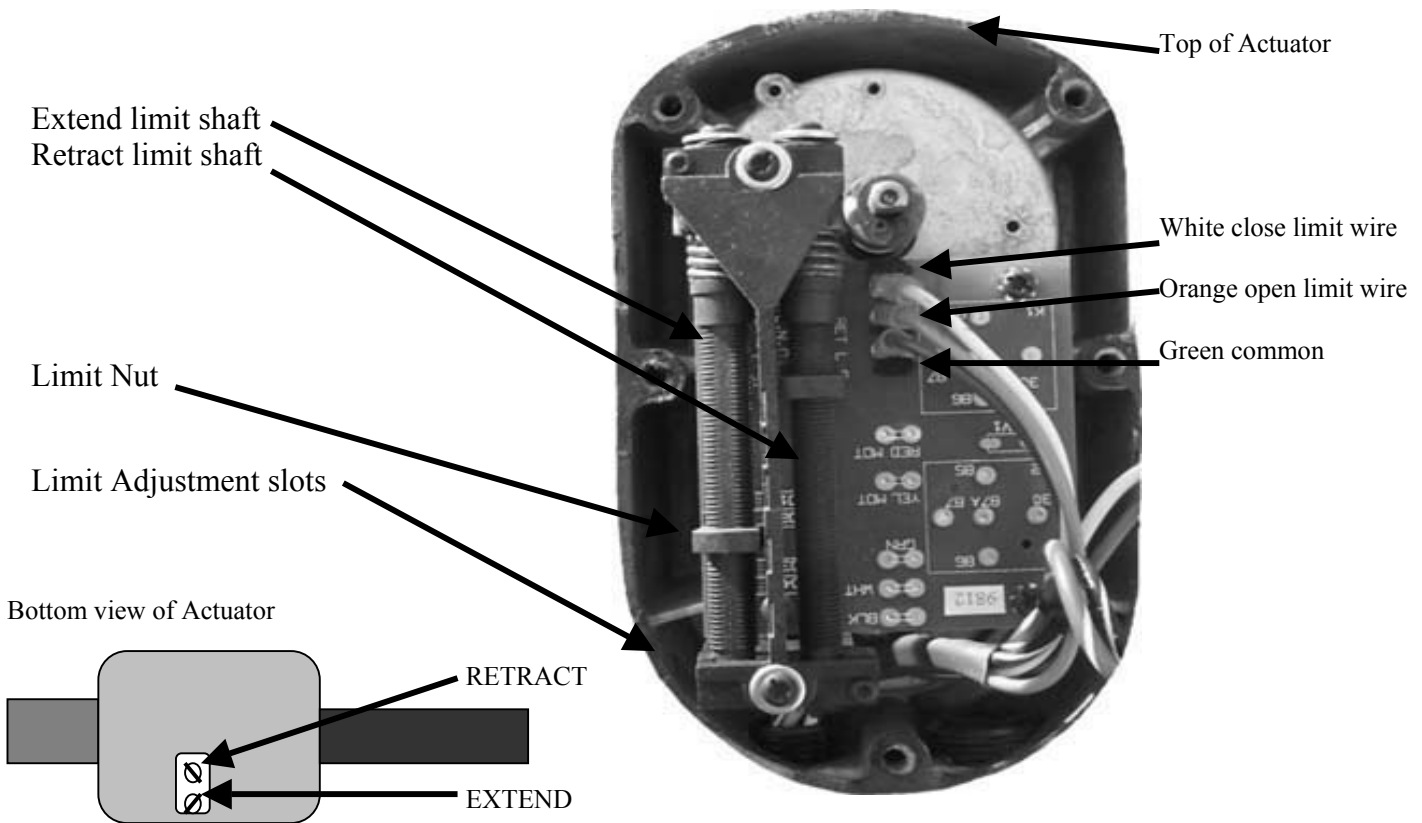

The following will assist you. Shown below are adjustments for pull to open installations. You can mount the actuator upside down to make adjustments easier, but do not leave actuator upside down.

To extend more or close gate more.
To extend less or close gate less.

Turn the extend adjust clockwise.
Turn the extend adjust counter clockwise.

To retract more or open gate more.
To retract less or open gate less.

Turn the retract adjust clockwise.
Turn the retract adjust counter clockwise.

Circuit Board Terminal Description For Accessories

Patriot Control Board

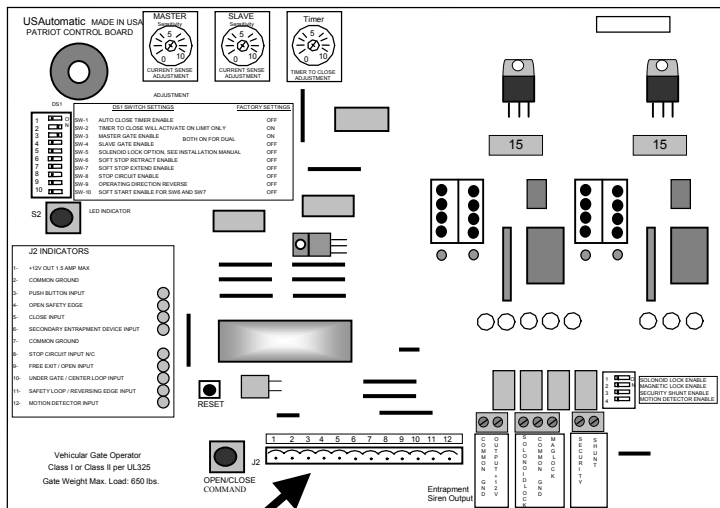

TERMINAL

DESCRIPTION

- | | |
|-----------|---|
| 1 | + 12 volt dc Output.
*Maximum current output 1.5 amp (1500 milliamps) |
| 2 | Common Ground Input |
| 3 | Push Button Input. (normally open contacts)
Push button, radio control, keypad, etc. |
| 4 | Open Safety Edge (normally open contacts)
(Stops gate when opening) |
| 5 | Close Input (normally open contacts) |
| 6 | Secondary Entrapment Input (normally open contacts) |
| 7 | Common Ground Input |
| 8 | Stop Circuit Input (normally closed contacts)
* DS1 switch #8 must be on for stop circuit function to be enabled. |
| 9 | Free Exit/Open Input (normally open contacts)
Loop input or any hold open input such as a 7-day timer, telephone access unit, or maintain contact switch (normally open contacts). These devices open the gate and will prevent the gate from closing if the contact is maintained. Once the contacts have been released, the gate can be closed with a closing signal device or the automatic close timer feature. |
| 10 | Center Loop or Under Gate Loop Input (normally open contacts) |
| 11 | Safety Loop/Reversing Edge Input (normally open contacts) |
| 12 | Motion Detector Input (normally open contacts)
(Stops a closed gate from opening)(Active on close limit only) |

DS1 Programming Switches

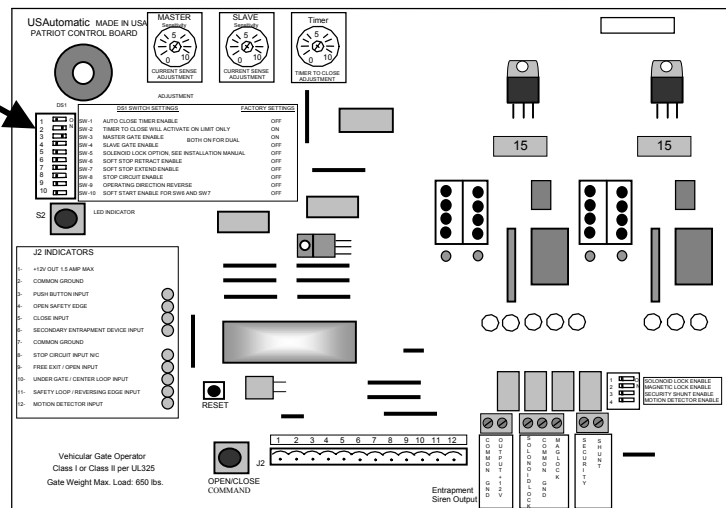

Factory settings are shown in bold italic type

- 1 Automatic Close Timer Enable
 ON Timer to close is activated
OFF *Timer to close is disabled*
- 2 Open limit timer to close function
 ON *Timer to close activates only if open limit is activated*
 OFF Timer to close works from any point the gate is stopped
- 3 Master Gate Enable
 ON *Master gate operator enabled to function*
 OFF Master gate operator disabled
- 4 Slave Gate Enabled (Both Master and Slave on for dual)
 ON Slave gate operator enabled to function
OFF *Slave gate operator disabled*
- 5 Solenoid Lock Option, See Installation Manual
 ON DS2 SW 1 must be on, output +12vdc with delay when gate is operating
OFF *No function, see DS 2 SW 1 for more information*
- 6 Soft Stop Retract Enable
 ON Enables soft stop for retract position
OFF *Disables soft stop for retract position*
- 7 Soft Stop Extend Enable
 ON Enables soft stop for extend position
OFF *Disables soft stop for extend position*
- 8 Stop circuit enable * A normally closed pushbutton is required
 ON Allows for a stop button input to be utilized
OFF *Disables the stop button function*
- 9 Operating Direction Reverse
 ON Push to Open
OFF *Pull to Open*
- 10 Soft Start Enable for SW6, SW7
 ON Enable Soft Start for Extend or Retract, Only if SW 6 or SW 7 or Both are ON.
OFF *No Soft Start (Must be used with SW6 and SW7)*

DS2 Programming Switches

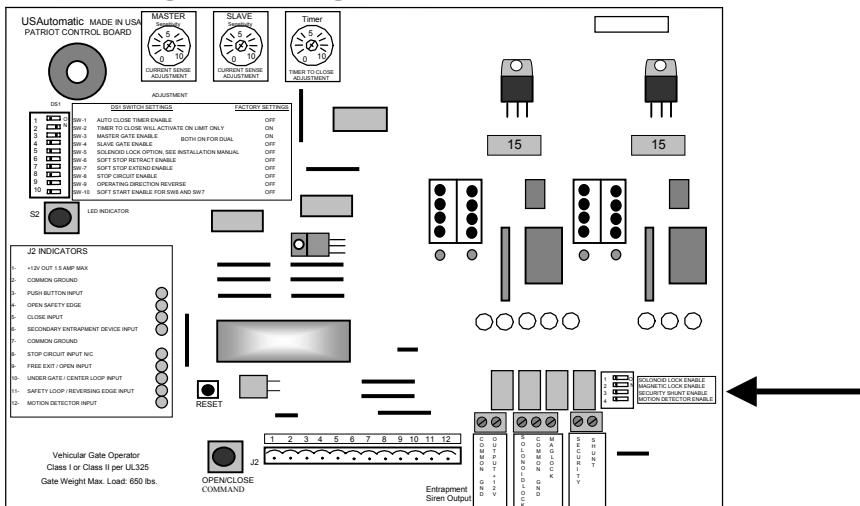

Factory settings are shown in bold italic type

- 1 Solenoid lock enable / Gate in operation indicator
ON Solenoid lock output energizes half second before gate begins to move and releases 3 seconds after gate begins to move, for gate in operation indicator to operate DS1 SW 5 must also be ON.
 (Energizes = +12 vdc output 1.5 amp max)
OFF *Solenoid lock / gate in operation indicator is inactive*
- 2 Magnetic lock enable
ON Magnetic lock output energizes on Master Limit and releases half second before gate begins to open
 (Energizes = +12 vdc output 1.5 amp max)
OFF *Magnetic lock output is inactive*
- 3 Security Shunt Circuit Enable / Open Gate Indicator
ON Security shunt circuit relay is active (closed circuit)(wire in parallel)
 Relay activates half second before gate begins to Open and stays activated until 4 seconds after gate reaches a closed limit.
OFF *Security shunt circuit relay is inactive (open circuit)*
- 4 Motion Detector Enable
ON Enables motion detector input J2 pin 12 (if input is activated, gate will not open)
OFF *Disables motion detector input J2 pin 12*

Emergency Manual Release

Remove the manual release pin at the gate bracket and open the gate by hand. Secure the gate before attempting to pass through.

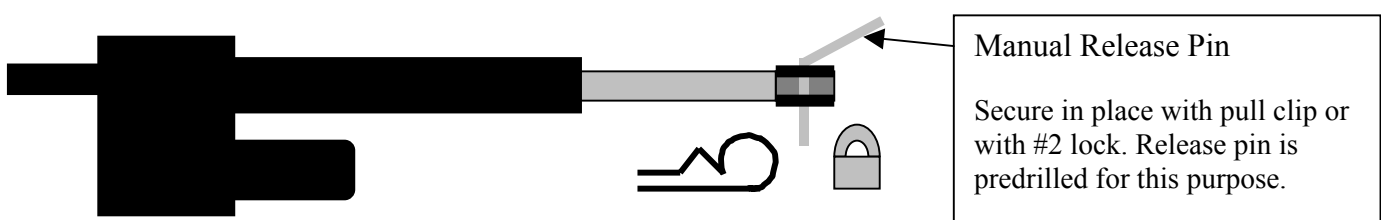

SAFETY SECTION

USAutomatic gate operators are certified to UL325 Vehicular Class I and Class II swing gate standards.

UL325 identifies four different classes of gate operators these classes are listed below:

- Class I:** Residential vehicular gate operator- a vehicular gate operator (or system) intended for use in a home of one to four single family dwellings or a garage or parking area associated therewith.
- Class II:** Commercial/General access vehicular gate operator- a vehicular gate operator (or system) intended for use in a commercial location or building such as multi-family housing unit (five or more single family units), hotel garages, retail store, or other buildings servicing the general public.
- Class III:** Industrial/Limited access vehicular gate operator- a vehicular gate operator (or system) intended for use in an industrial location or building such as a factory or loading dock area or other locations not intended to serve the general public.
- Class IV:** Restricted Access vehicular gate operator- a vehicular gate operator (or system) intended for use in a guarded industrial location or building such as an airport security area or other restricted access locations not servicing the general public, in which unauthorized access is prevented via supervision by security personnel.

Patriot I and Patriot II gate operators are intended to be installed as Class I or Class II vehicular gate operators, and the maximum load of each gate leaf should not exceed 650 pounds with a length not to exceed sixteen feet.

SAFETY SECTION

INSTALLATION

Install the gate operator when:

- The operator is appropriate for the construction of the gate and the usage class is correct for the installation.
- All exposed pinch points are eliminated or guarded.
- Only install on vehicle gates, pedestrians must be supplied with a separate access opening.
- The gate is installed in a location where enough space is supplied between adjacent structures and the gate that when opening or closing the chance of entrapment is reduced.
- Swing gates shall not open into public access areas.
- The gate is properly installed and swings freely in both directions. Do not over adjust the sensitivity adjustment to compensate for an improper gate installation.
- Locate all controls at least six feet away from the gate to eliminate the chance of the person operating the gate from coming in contact with the moving gate. Do not install external buttons, which can be used to operate the gate within the reach of children.
- All placards must be installed one on each side of the gate visible in the gate area.
- Contact sensors used for secondary entrapment safety devices and their wiring must be installed in a manner protects them from mechanical damage.
- Non-Contact sensors used for secondary entrapment safety devices must be located so that the signal from the transmitter to the receiver is not interfered with by adjacent structures. All exposed wiring must also be protected from mechanical damage.

SECONDARY ENTRAPMENT DEVICES

USAutomatic has designed all control boards with secondary entrapment device inputs and secondary safety devices must be installed with all installations. USAutomatic recommends the use of UL325 listed safety devices.

NOTE: *USAutomatic recommends that these devices be CONNECTED after proper gate installation and operation has been verified. Then connect one device and verify proper operation before installing the next device. Ensure that power is disconnected from the control board prior to connecting any wires to the control board.*

WARNING: TO REDUCE THE RISK OF INJURY OR DEATH

1. **READ AND FOLLOW ALL INSTRUCTIONS**
2. **Never let children operate or play with gate controls. Keep remote control away from children.**
3. **Always keep people and objects away from the gate.**
4. **NO ONE SHOULD CROSS THE PATH OF A MOVING GATE.**
5. **Test gate operator monthly. The gate must stop and reverse directions upon contacting a rigid object or when the secondary entrapment device is activated.**
6. **After all adjustments have been made to the limit switches, sensitivity (current sense) circuit, secondary entrapment devices and all other external devices installed the safety devices must be checked again. Failure to adjust and retest the gate operator can increase the risk of injury or death.**
7. **Verify that the emergency release (manual release) pin can be easily removed. This should only be checked when power is disconnected from the operator.**
8. **KEEP GATES PROPERLY MAINTAINED. Read the user manual and have a qualified service technician make repairs to the gate hardware.**
9. **THE ENTRANCE IS TO BE USED BY VEHICLES ONLY. Pedestrians must use a separate entrance.**
10. **SAVE THESE INSTRUCTIONS**

SAFETY SECTION

All safety features required by UL 325 are incorporated in the capabilities of all USAutomatic Control boards and should be utilized, including but not limited to, safety edges, photo electric eyes, reverse sensing, and motion sensing.

Cautions - Very Important

- Do not attempt to enter the gate area while the gate is moving. Wait until the gate comes to a complete stop.
- Operate the gate only when it is fully visible, free of persons or obstructions, and properly adjusted.
- Do not allow children to play in the area of the gate. Do not allow anyone to ride on the gate.
- Do not allow children to play with the remote control or any other activation device. Do not attempt to "beat the gate" while the gate is opening or closing. This is extremely dangerous.
- Test the current sense feature and all safety devices regularly to insure correct operation.
- Study this entire Safety Section paying particularly close attention to the entrapment zones shown below and be aware of these areas not only during use but also during any adjustments to the unit.

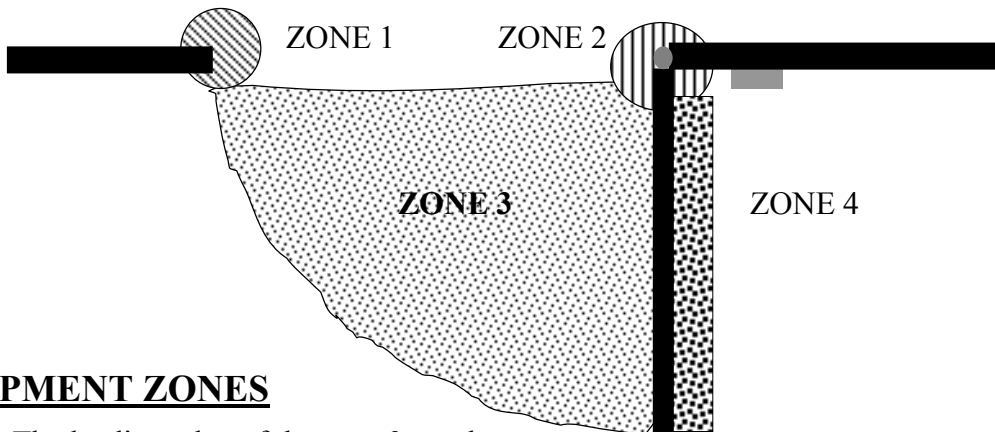

ENTRAPMENT ZONES

- Zone 1 The leading edge of the gate & catch post.
- Zone 2 Between the gate and hinge post.
- Zone 3 The arc of the gate or gate path.
- Zone 4 The space between the gate when open and any obstruction such as fence, wall, landscaping, etc
- Zone 5 (Not shown above see page 20) the point where two bi-parting gates come together when closing. This is similar to Zone 1.

SAFETY SECTION

Remedies for Safety Concerns

Zone 1 Safety edges and photo electric eyes are the most common types of protection available.

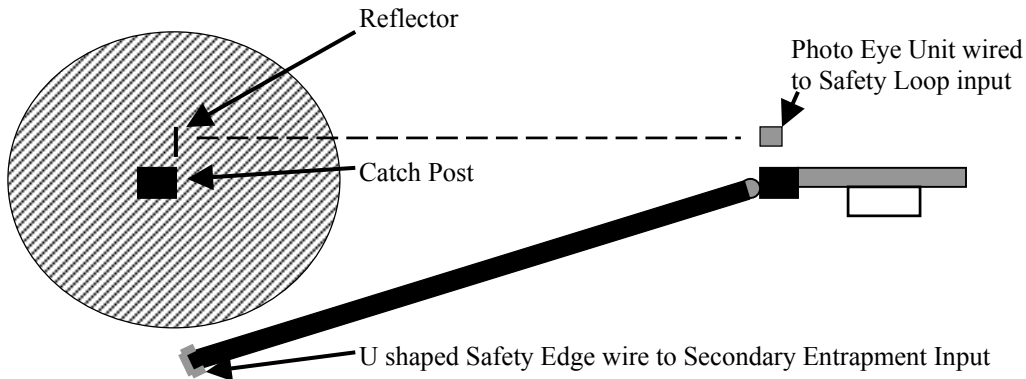

Zone 2 A safety edge may also be utilized here but the best remedy is to eliminate pinch points when designing the hinges. Most injuries at this point result from negligence, such as reaching through the hinge area or the gate to activate a button, key switch, etc.

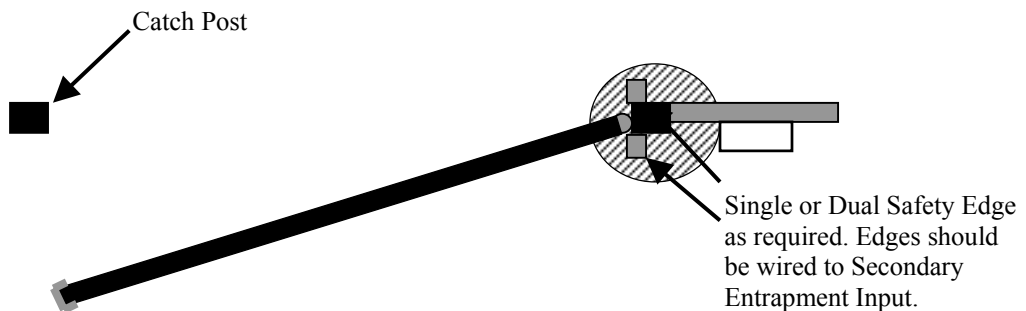

NOTE: All control stations should be located at least 6 feet from any moving part of the gate or operator.

Never install any control device where a user will be tempted to reach through the gate or fence to activate a gate.

SAFETY SECTION

Remedies for Safety Concerns

Zone 3 Safety edges are the best protection. A photo eye may also be used. For vehicle traffic, magnetic vehicle detectors and wire sensing loops are preferred.

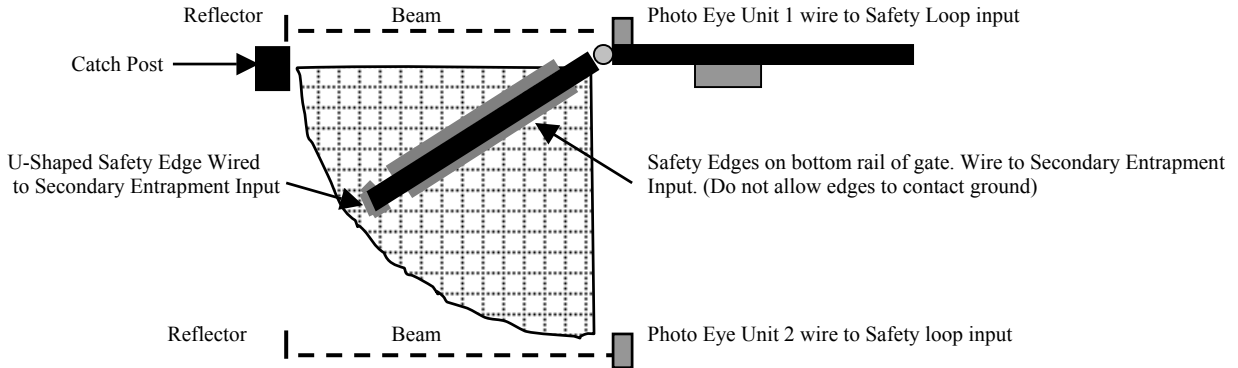

Zone 4 This area is best protected with a photo eye wired to the secondary entrapment input. The beam should be installed parallel to the gate in the open position or along the obstructing wall or fence.

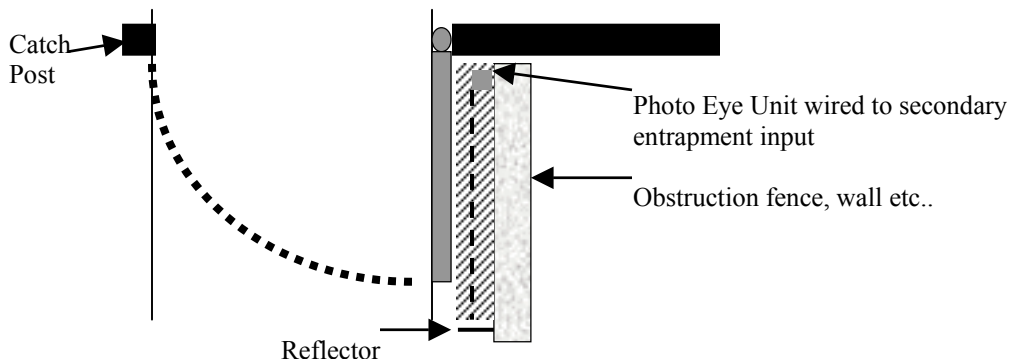

Zone 5 Safety edges and photo eyes are the most common types of protection available.

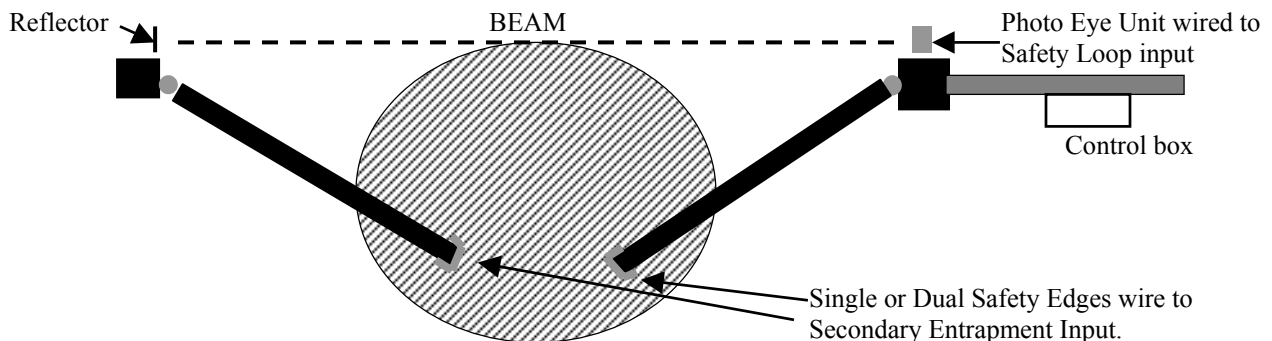

NOTE: *When gates are fully closed Safety Edges must not contact each other. This can cause false obstruction sensing*

Every installation is unique and it is the installer's responsibility to recognize and remedy all safety concerns. Please consult a qualified dealer or the factory for a complete explanation of the remedies shown above and additional tips pertaining to your installation.

Periodic Service

All gate operators require periodic checking and adjustments by a qualified technician of the control mechanism for force (load), speed and sensitivity. All external accessories and secondary safety devices must be checked. Secondary safety devices need to be checked at least once a month for proper operation.

Periodic checking is also advised for the following:

1. Battery cells water level. (Use distilled water if needed)(Sealed Gel batteries preferred)
2. Hinges and pivot points need to be greased.
3. Bolts for correct tightness.
4. Inspect weld points for cracks or other defects.
5. Inspect wiring for cuts, nicks or other defects.
6. Inspect hinge post to ensure it is not moving or twisting.
7. If AC charger is used verify proper charger operation, refer to charger instructions.
8. Verify that the inside of the control cabinet remains clean and free of insects. Do not spray control board with bug spray.

Troubleshooting Guide

Introduction

The Patriot control board is equipped with three unique features to assist in troubleshooting a gate system.

1. The first and most helpful is the series of LED indicating lights. These lights will help to identify problems with the actuator limit switches and all control circuits. To use the indicators, press and hold the “LED indicator” button on the control board. (The LEDs are not active at all times to save battery life). Any circuits or limit switches that are activated will be obvious by the illumination of the adjacent LED.
2. The second feature to assist in troubleshooting is the current sense beeper. The beeper will sound anytime the current sense circuit is activated. This is useful in detecting a false reverse due to an improper or too sensitive current reverse setting or a gate, which is requiring excessive force to move the gate.
3. The third feature to assist in troubleshooting is the on board open/close command pushbutton. This button makes it possible to operate the gate with the twelve terminal wiring plug removed without having to short across terminal pins.

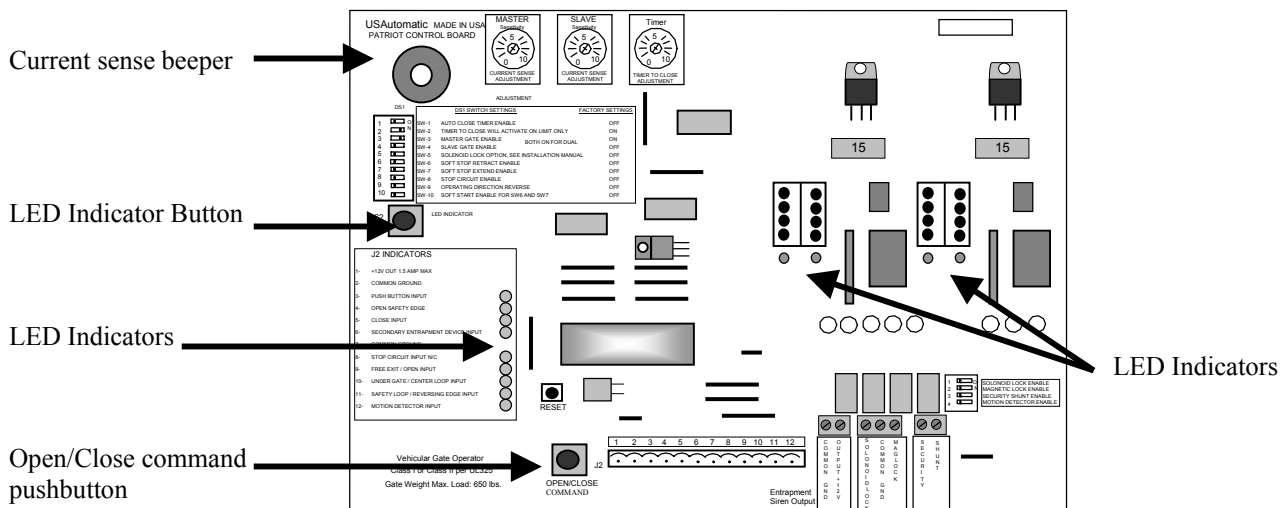

TROUBLESHOOTING SECTION

OUTLINE

- 1 Single gate will not operate.
- 2 Dual gate will not operate.
- 3 Single or Dual gate opens or closes very slow.
- 4 Gate will not automatically close.
- 5 Gate begins to open or close, but stops and reverses after a couple of seconds.
- 6 Single Gate opens correctly then closes immediately or single Gate closes correctly and then opens immediately.
- 7 Dual Gate opens correctly then closes immediately or dual Gate closes correctly then opens immediately.
- 8 Control board 15 amp fuse blows when open/close command is given.
- 9 Transmitter (Remote control) will not operate the gate.
- 10 Photo eye, safety loop or other safety accessory will not reverse the gate when closing.
- 11 Pressing the “RESET” button only, causes the gate to operate.

Terms and Definitions

- LED - Light emitting diode, small red lights on control board.
- Control board- Located inside the metal box just above the battery.
- Receiver - Located inside the metal box in the upper right corner, coax cable connected to it.
- Transmitter - Hand held push button, which is used to operate the gate, sends signal to receiver.
- Actuator - Connected to gate and hinge post, contains the motor, gearbox and extension tube.
- Connector - Control board has two types. Two white 8-pin connectors (X1 and X2) are used to connect actuator to control board and one green 12-pin connector (J2) (located bottom center of control board) to connect receiver and accessories to control board. Both are plug type and can be disconnected (unplugged from control board) without disconnecting wires.
- Dip Switches - Small switches, which are located on the control board in two places. The primary set DS1 is located in the upper left corner and the secondary set DS2 are located in the lower right corner of the control board with functions listed beside each. See manual (page 15, 16) for more information.
- Push Buttons - Three are located on the control board. “Open/Close command” used to operate the gate, “Led Indicator” used to activate the leds and the “Reset” used to reset the control board after current sensing twice before a limit is reached.

1. My single gate will not operate Patriot I:

- STEP 1 Remove control box cover locate the “Open/Close Command” push button and press it to operate the gate.
- STEP 2 Press the “Reset” push button located above the open close command, then push the “open/close command” push button to operate the gate.
- STEP 3 When pressing the “open/close command” push button, listen for a clicking sound, if click is heard then verify: The 15-amp fuse located on the control board is good if not replace it using the spare located on the control board. Also check the dipswitches (3 and 4) for correct switch settings based on where the actuator is connected to the control board (Master or Slave). If switches and fuse are good and clicking sound is heard the battery needs to be load tested to determine its condition. Charge or replace depending on results.
- STEP 4 Press and hold the “LED Indicator” push button and observe all of the red LED’s (see page 18 for location):
- If the two limit LED’s located below the actuator plug are both on the operator will not operate, you must adjust the limit switch (see page 10) Example- if both limit LED’s are on when the gate is in the closed position (and actuator is connected to the gate) the problem is with the open limit switch, adjust the open limit until the LED goes off and adjust the gate to the desired stopping position. Both LED’s should never be on simultaneously.
 - If any of the LED’s in the lower left corner of the control board are on then this must be corrected. Locate the accessory, which is activated, and repair or replace. Disconnecting this device will allow the operator to work, without the disconnected accessory function.
- STEP 5 Disconnect the green J2 connector. Once disconnected, press the “open/close command” button. If gate operates go to step 4 b above.
- STEP 6 Verify that DS1 switch 8 is off.
- STEP 7 Call the factory for more information if the above steps have not worked.

2. My dual gate will not operate Patriot II:

- STEP 1 Follow steps 1 through 6 above.
- STEP 2 Disconnect the actuator connectors plugged into the control board (X1 and X2). Then locate the DS1 dipswitches on the control board. Turn off switch 4 (slide to the left) and turn on switch 3 (slide to right).
Reconnect the connector from the actuator that goes to the gate closest to you; connect it to the Master (X1) connector on the control board. Press the “open/close command” button and verify that the gate operates.
- STEP 3 If the gate operates correctly, disconnect the actuator plug and connect the other actuator plug into the X1 connector, and press the “open/close command” button and verify that the gate operates correctly. At this point you have tested each actuator individually. If both worked correctly then go back to DS1 and turn switch 3 off and switch 4 on. Then repeat step 2 and 3 again using X2 connector on control board in place of X1.
- STEP 4 If a problem is observed in steps 2 or 3 above most likely it was when the slave actuator (located the greatest distance from control box) was being tested, if this is correct check wiring splices for moisture, correct wiring and etc. If the wiring is not in watertight conduit and this is most likely the problem. Tape is not watertight.

3. My gate opens/closes very slow:

NOTE: When the gate is running slow the reason is low battery voltage, two things need to be considered. Battery condition (replace or charge) and what caused the battery to become discharged.

- STEP 1 Determine which situation your operator falls into below:

Solar charged, ensure that you have a deep cycle battery installed and if accessories are connected (keypads, loop detectors, any device powered by the battery) verify that the current draw needed to power them does not exceed the charging power of the solar panel. Verify that solar panel leads are connected to the battery correctly; panel is facing a southwest direction and is not located in a completely shaded area. Inspect panel surface and wires for damage.

Test solar panel for correct voltage and current output, disconnect panel wires from battery and using a DC voltmeter measure the dc voltage (should measure about 22 volts) and the dc current (should read about 250 ma) in the peak sun period. If either, of these readings is incorrect panel maybe defective.

If none of the above check bad then remove battery and have it load tested at a battery shop. Replace if bad.

AC charged, ensure that you have a deep cycle battery rated at a minimum of 60 amp-hour installed. If accessories are connected (keypads, loop detectors, any device powered by the battery) verify that the current draw needed to power them does not exceed the charging power of the charger. Verify that charger leads are connected to the battery correctly; charger is connected to an approved 110 VAC receptacle. Inspect charger and wires for damage.

NOTE: The USAutomatic multi stage charger does not output any voltage or current when disconnected from the battery, you cannot check charger by disconnecting from battery and measuring voltage output. To check charger output disconnect from battery, measure battery voltage and note. Reconnect charger and monitor battery voltage it should rise above the battery voltage noted above.

STEP 2 The charger has LED indicators (lights) on the faceplate, observe the LED's that are on or not and refer to the troubleshooting directions furnished with the charger for definitions of different LED indicators.

STEP 3 If none of the above check bad then remove battery and have it load tested at a battery shop. Replace if bad.

4. My gate will not automatically close:

NOTE: If DS1 switch 1 is on and switch 2 is off then the gate should automatically close from any position, but if switch 2 is also on the gate will only automatically close if the "open limit" LED (both "open limit" LED's for dual gate) is on.

STEP 1 Locate the "Open/Close Command" push button; press the button to verify that the gate will close. If gate closes correctly then proceed to the steps below.

STEP 2 Verify that DS1 switch 1 is on. If not turn it on and recheck gate operation. If gate remains open continue with step 3.

STEP 3 If your installation is a single gate, then only DS1 switch 3 or 4 can be on. If both are on the gate will not automatically close. Turn off the one that is not being used and recheck gate operation.

STEP 4 Locate the "LED Indicator" push button and depress and hold. While pushing the button inspect the LED indicators located just below the X1, X2 (master, slave) actuator plugs, note which LED's are on. Read note below.

NOTE: The two LED's located below the X1, X2 actuator plug when on represent the closure of the limit switch. If the left LED is on then the gate should be in the open position, if the LED on the right is on then the gate should be in the closed position. If DS1 switch 9 (operating direction reverse) is on then this is reversed. If the LED for the open position is not on when the gate is fully opened then the auto close will not work. The limit switches need to be adjusted.

STEP 5 Locate the "LED Indicator" push button and depress and hold. While pushing the button inspect the LED indicators located on the control board (lower left corner) and note which LED's are on. If any LED's are on disconnect the green J2 connector from the control board. Press the "Open/Close Command" push button to close the gate, and then press the button again to open the gate fully and verify the automatic close is working.

STEP 6 If gate automatically closes correctly then the accessory connected to the J2 connector that is activated (LED is on) needs to be repaired.

5. Gate begins to open or close but stops and reverses after a couple of seconds.

STEP 1 Remove control box cover and locate the Patriot control board. Locate the sensitivity adjustment (see page 12) potentiometer located on the control board. The white center is adjustable and needs to be turned in a clockwise direction.

STEP 2 Normally a setting of 5 will operate most gates; if your gate requires a setting above 8 there is a good chance that your gate has a problem, which needs to be corrected. Possible causes are incorrect hinges, gate touching the ground; gate not level or the actuator arm connected to the gate has been bent. Identify and correct problem.

6. Single Gate opens or closes correctly then immediately reverses direction:

STEP 1 This is most likely caused by an incorrect limit switch adjustment. The limit switch adjustments are located on the bottom of the actuator motor housing, behind the removable rubber plug. Locate the limit switch adjustment screws and determine which one needs to be adjusted (see page 12). Operate the gate and once it reaches the desired open or close position stop the gate in that position, using the transmitter or "Open/Close Command" push button located on the Patriot control board.

STEP 2 Locate the "LED Indicator" push button located on the left side of the Patriot control board. Also locate the open and close LED indicators below the actuator plug on the Patriot control board. The left LED represents the open position and the right LED represents the close position. (See note below)

STEP 3 With the gate in the desired open or close position press and hold the "LED Indicator" and observe which of the LED lights come on. If your gate is in the desired open position then the LED on the left should be on, if not adjust the retract limit switch (see page 13) until the LED comes on. If gate was in the close position adjust the extend limit switch until the close LED comes on.

NOTE: If DS1 switch 9 is turned on, then the open and close LED's are reversed. Open LED represents the closed position and the close LED represents the open position.

STEP 4 Once adjusted correctly the open LED should be on when the gate is opened and the close LED should be on when the gate is closed.

STEP 5 If the LED's will not come on then contact the factory.

7. Dual Gate opens or closes correctly then immediately reverses direction:

- STEP 1 This is most likely caused by an incorrect limit switch adjustment. First determine which gate is in need of adjustment.
- STEP 2 Locate the DS1 switches on the Patriot control board. Switch 3 and 4 should be turned on for a dual gate, turn off switch 4 this will disable one gate.
- STEP 3 Operate the gate and verify that it stops in the correct position, if so then turn switch 4 back on and turn off switch 3. Operate the other gate now and verify that it stops in the correct position. One or both should not stop in the correct position.
- STEP 4 Once the gate that needs adjustment is identified (possibly both) refer to problem 6 above steps 1 through 5 for instructions.

8. Control board 15 amp fuse blows when open/close command is given.

- STEP 1 Fuses blow primarily for one reason, the gate cannot move. Causes might be something keeping the gate from moving, the gate is trying to move in the wrong direction due to incorrect limit switch setting or there might be a wiring problem. A wiring problem is most likely in a splice that might have been made during installation or it could be in the actuator housing.
- STEP 2 Open the control box and locate the Patriot control board, locate the 2 LED's under the actuator connector on the control board. Press the "LED indicator" push button and hold it in, observe the LED's and determine if the open limit or close limit LED is on. Then determine if the correct LED is on for the gate position. For example if the left LED is on that is the open limit and the gate should be in the open position. The right LED represents the closed position. See note under problem 4 above.
- STEP 3 If the open limit LED is on and the gate is closed if a command to operate is given the gate will try to close more, which can blow a fuse. If the close limit LED is on and the gate is opened a command to operate will try to open the gate more, which can blow a fuse. In either case the limit switches need to be adjusted and then the cause for them becoming misadjusted needs to be determined. The cause generally has to do with wiring; bad actuator plug connection at the Patriot control board or too much adjustment has been made during installation.
- STEP 4 If a wiring problem is suspected the orange, white and green wires are the ones to concentrate on. Check all splices and verify actuator connector is connected at the control board.
- STEP 5 If the actuator is suspected of being bad either due to an internal wiring problem or a motor problem, call the factory for further troubleshooting and return information.

9. Transmitter will not operate the gate

- STEP 1 Open the control box and locate the Patriot control board. Locate the "LED Indicator" push button and the "Push Button Input" LED. Push the "LED indicator" push button and hold, then press the transmitter button and observe the "push button LED". The LED should come on while the transmitter button is depressed.
- STEP 2 If the "Push Button LED" did not come on then make sure that the green J2 connector on the control board is securely connected, replace the 9 volt battery in the transmitter and verify that the dip switches located in the transmitter (above battery) are set identical to the ones located in your receiver. Remove the receiver cover by squeezing the sides and locate the switches inside.
- STEP 3 If the "Push Button Input" LED in step 1 did come on and the gate did not operate then locate the "Open/Close Command" button located at the bottom center of the Patriot control board. Press the "Open/Close Command" button and note gate operation.
- STEP 3 If the gate did not operate in step 3 verify that the 15-amp fuse on the Patriot control board adjacent to the actuator plug being used is not blown, (a fuse can be blown and look good) replacing is the best way to verify fuse is good.
- STEP 4 If the gate did not operate in step 3 and the fuse was good in step 4 then most likely a safety accessory connected to the green J2 connector is active. Verify this by depressing the "LED Indicator" push button and observe the LED's located in the lower left corner of the Patriot control board. If a led is on identify the accessory connected to the corresponding J2 connector pin and correct the problem.
- STEP 5 Other causes are possible, both the open and close limit LED's are on at the same time, if so adjust limit switches. Control board could be defective; battery could be too weak to operate the gate. Please call the factory for help identifying the cause.

10 Photo-eye, safety loop or other safety accessory will not reverse the gate when closing or hold the gate open

- STEP 1 The first thing to check is the accessory wiring. The accessory needs power (+12vdc) wired to battery positive terminal or to J2 pin 1 on the Patriot control board. It also needs ground, which can be wired to the battery or to J2 pin 2 or 7 on the Patriot control board. The other two connections are the “N/O and Common ground”. The common ground can be connected to the battery or to J2 pin 2 or 7 on the Patriot control board. The N/O connection must be connected to J2 pin 11 “Safety Loop / Reversing Edge Input”. If the accessory is connected as described above it should reverse a closing gate or hold a gate open if the accessory is activated.
- STEP 2 Now to determine if the accessory is working correctly and that the Patriot control board is receiving the signal locate the “LED Indicator” push button and the “Safety Loop / Reversing Edge Input” LED (located in the lower left corner of the Patriot control board).
- STEP 3 Press and hold the “LED indicator” push button and observe the “Safety Loop / Reversing Edge Input” LED. Activate the accessory in question (if photo-eye break the beam) if the accessory is working properly the LED light should come on when the device is activated. If the device does not turn on the LED light then check wiring, J2 connector connection at the Patriot control board. If wiring is good then the accessory is not operating correctly. Repair accessory and retest.
- STEP 4 If the “Safety Loop / Reversing Edge Input” LED comes on and the gate does not reverse direction when closing, call the factory for other possible causes and return information.

11 Pressing the “RESET” button only, causes the gate to operate

- STEP 1 This problem is probably due to a bad receiver. First locate the “LED Indicator” push button on the Patriot control board. Then locate the “Push Button Input” LED located in the lower left corner of the Patriot control board.
- STEP 2 Press the “LED Indicator” button and observe the “Push Button Input” LED. If the LED comes on then the receiver relay is stuck closed and needs to be repaired or replaced.
- STEP 3 If the “Push Button Input” LED does not come on, call the factory for further troubleshooting and return information.

ACCESSORY WIRING DIAGRAMS

NOTE: Ensure that battery power is disconnected from the control board before wiring accessories to the control board.

Single Button Station to Open/Close

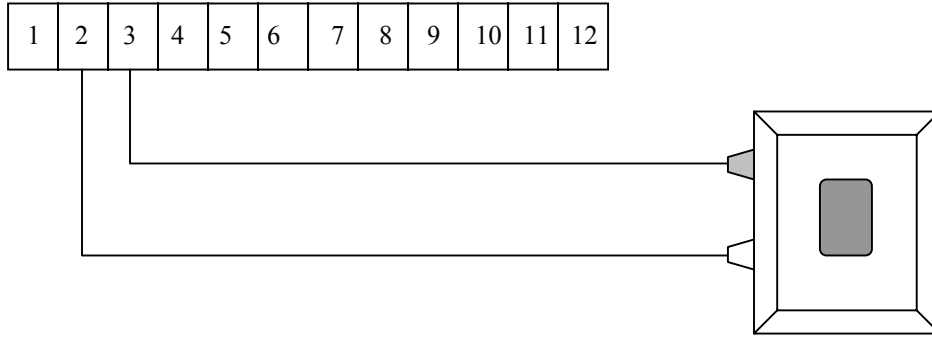

3 Button Station Wiring

Note: Program function switch DS1 #8 must be in the on position for stop button control

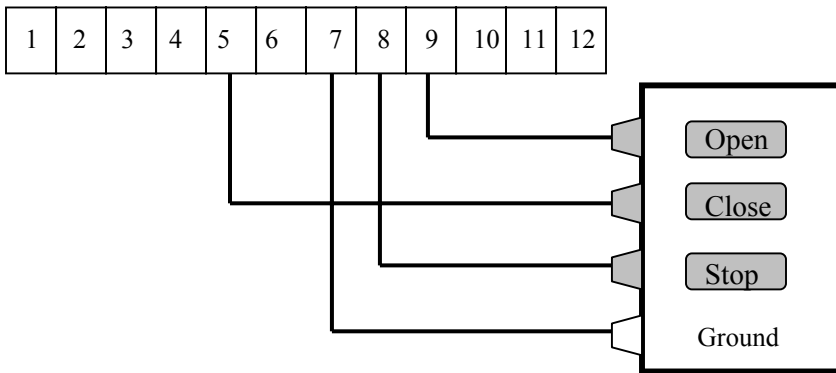

Seven Day Timer to Hold Gate Open – TH800-12

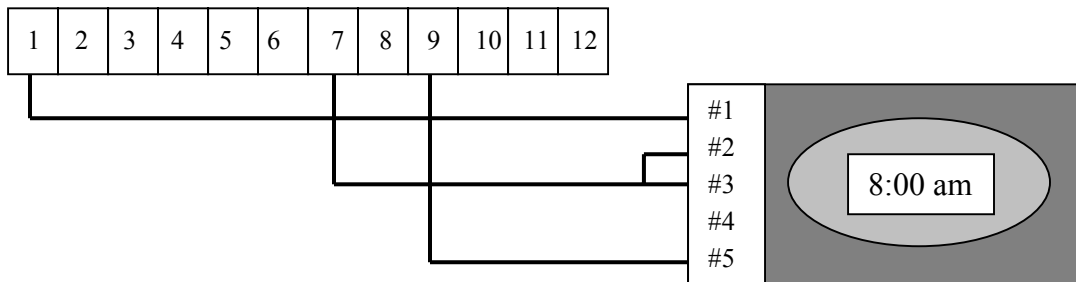

Radio Receiver Multi-Code 1099-40 or Digi-Code 5100

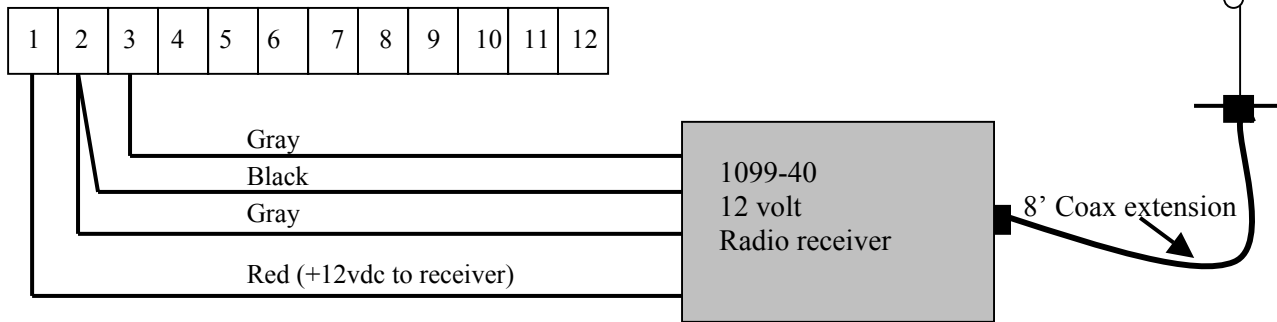

Radio Receiver Allister 9931-LV 3 wire with F Connector

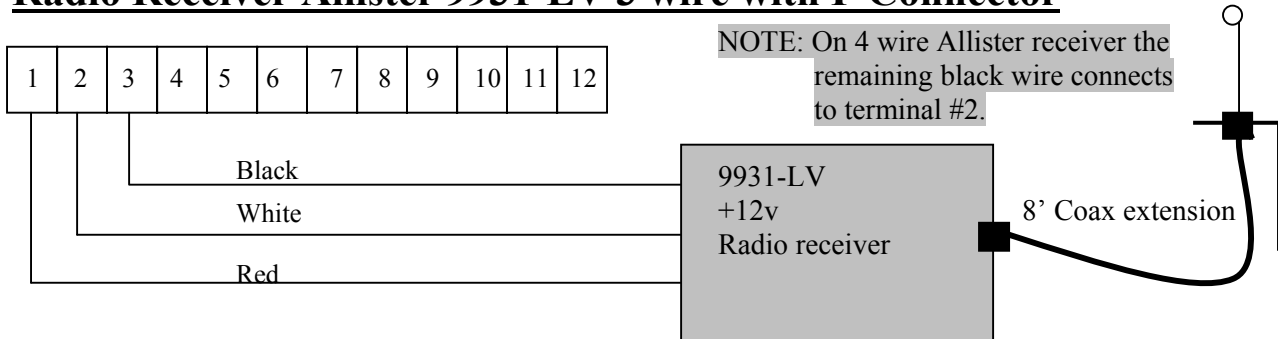

Radio Receiver Lift Master 412 HM

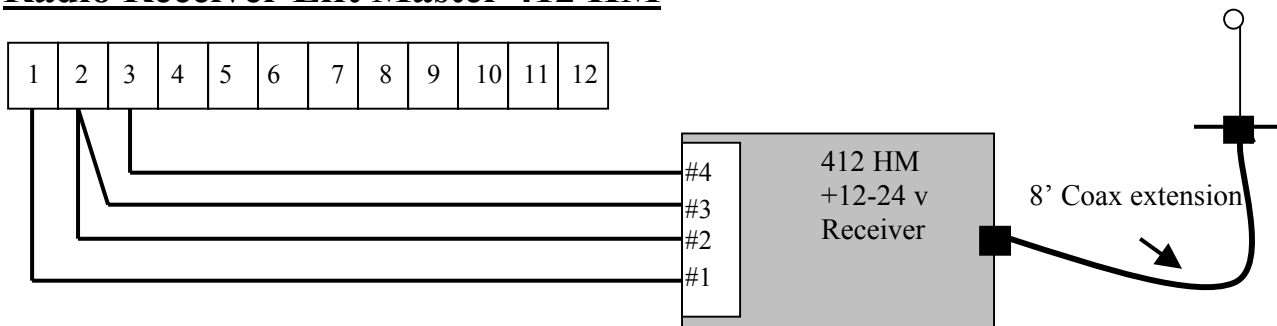

Radio Receiver Linear DRA-F 12 Volt

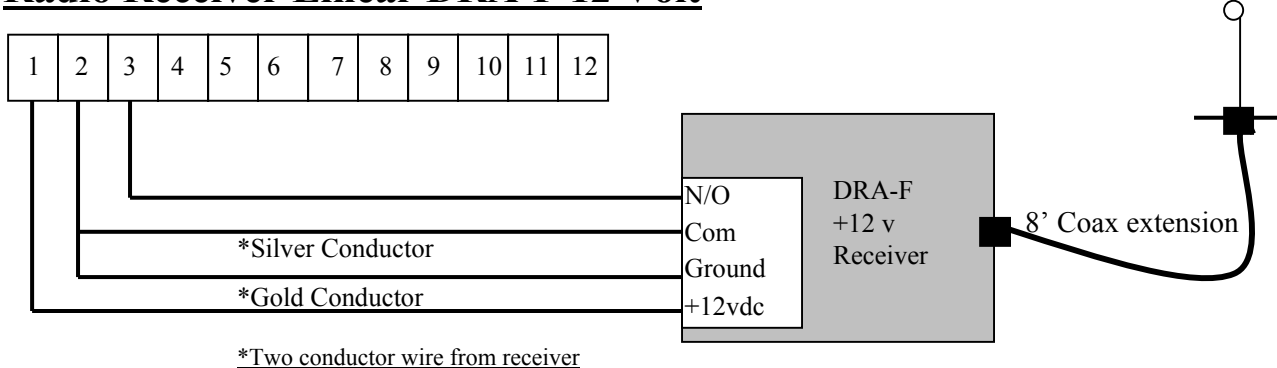

Albano Receiver: (Long Range) Single Channel

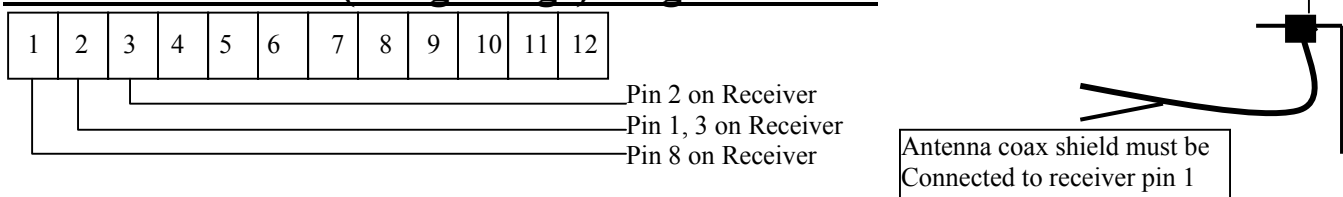

Keypad (12 Volt D.C.)

(Momentary Contact Signal)

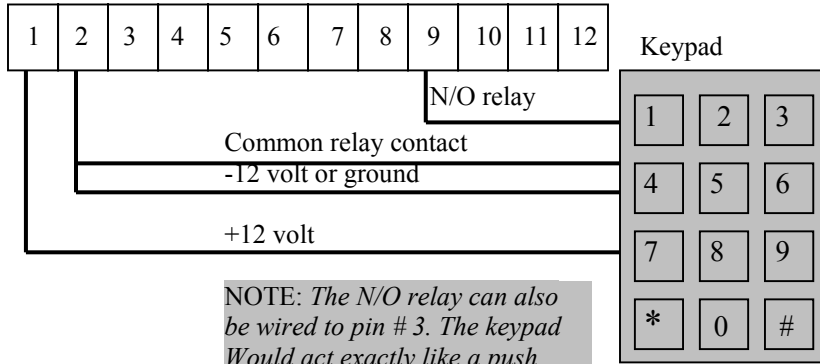

NOTE: The N/O relay can also be wired to pin # 3. The keypad would act exactly like a push button transmitter when code was entered. Maintain open pin # 9.

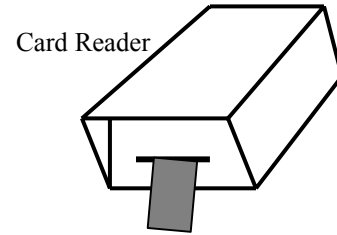

OR

Telephone Access Unit Wiring Signal or Hold Open Signal

(Hold open circuit with timer to close override)

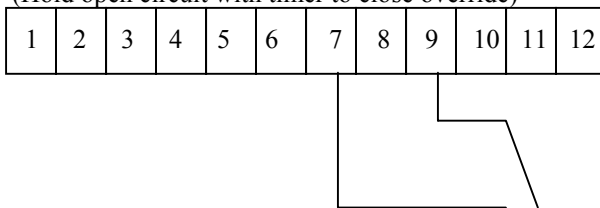

Normally open contacts from any device such as a Free Exit Loop, Maintain Contact Key switch, 7-Day Timer, Telephone Access Unit etc. When the switch contacts close, the gate will open and remain open until the contacts are released. The Close Timer or any close signal will only operate after the switch contacts open.

Photo Eye Wiring for Secondary Entrapment Device

(+12 volt Photo Eye) Wiring shown for Allen Bradley Model # 42GRU-9001

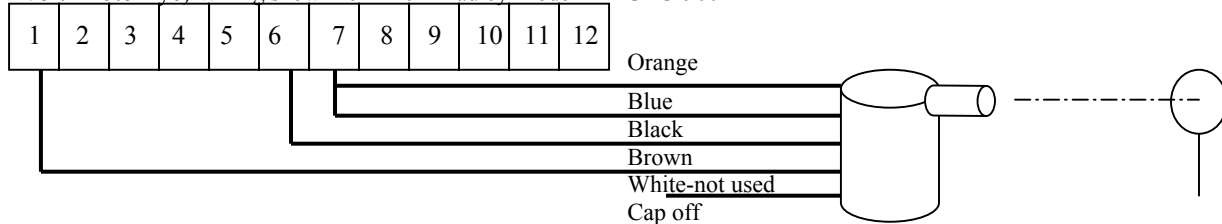

➤ Stop circuit wiring also available, consult factory

Safety Edge Wiring (Wired Type) Secondary Entrapment Device

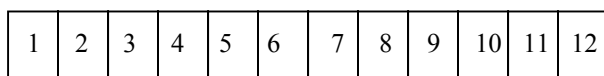

➤ Stop circuit wiring also available, consult factory

Probe Free Exit Magnetic Detector

Wiring shown for MFM sensors Model # MFM-D376 LC / EMX car sense 101

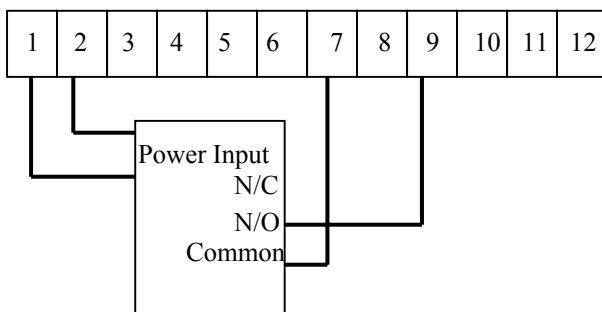

NOTE: This type of detector senses moving vehicles only. It should be utilized as an opening device only. If used as a safety device, the gate will close if the vehicle stops and possible damage will result.

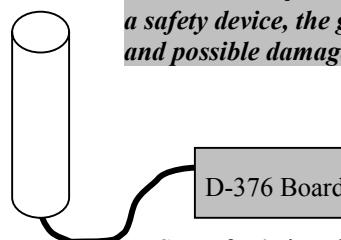

See mfg.'s installation instructions
For probe wiring.

Safety Edge Wiring (Wireless Type) Secondary Entrapment Device

(Safety Edge Transmitter & Radio Receiver)

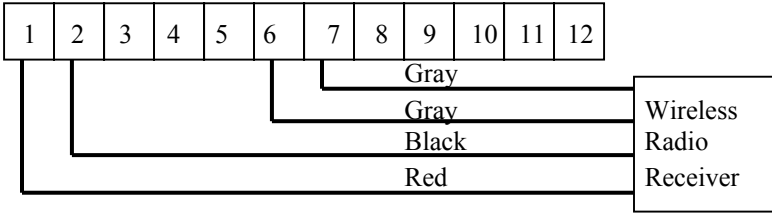

This receiver is for Safety edge only.
Another receiver is required if a Transmitter is used to open the gate

NOTE: Transmitter battery will be drained if Contact edge on gate is depressed constantly.

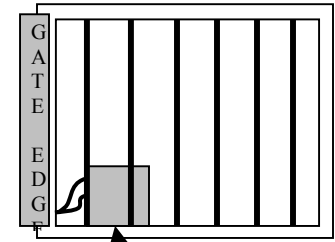

Wireless transmitter connected to gate contact edge.

➤ Stop circuit wiring also available, consult factory

Safety Loop Magnetic Vehicle Detector 12 Volt DC

Wiring shown for Reno Model # BX-LP or BX-LP-SS detector (See Wiring Note Below)

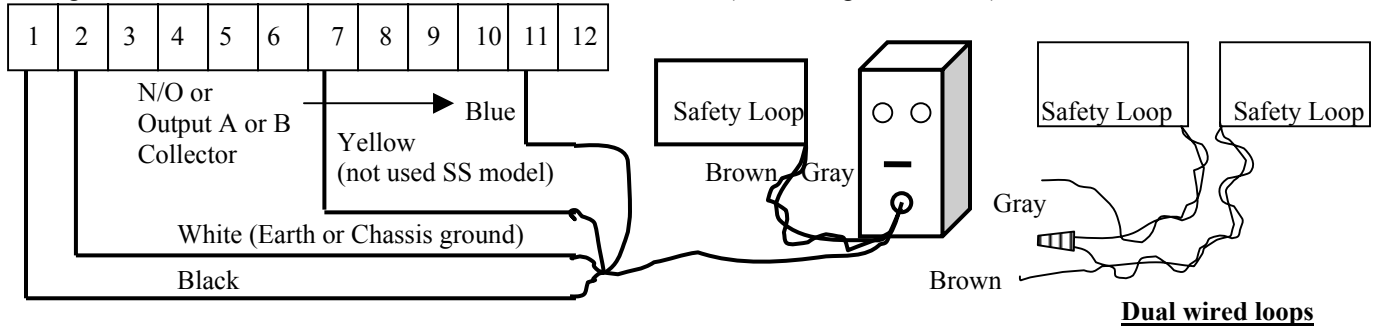

Free Exit Loop Magnetic Vehicle Detector 12 Volt DC

Wiring shown for Reno Model # BX-LP or BX-LP-SS detector

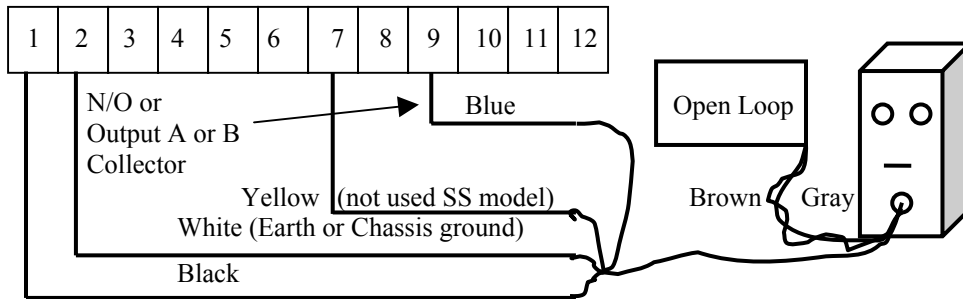

Wiring Note: When using the SS model detector connect detector pins 2 (“power -“) 5 and 9 (“Output A, B Emitter”) together and connect them to pin 2 on the control board.

Connect the detector pin corresponding to “output A or B Collector” to the desired pin on the control board. Pin 9 free exit, pin 11 for safety loop.

Safety Loop Magnetic Vehicle Detector 12 Volt DC

Wiring shown for Diablo Model # DSP-5LP detector

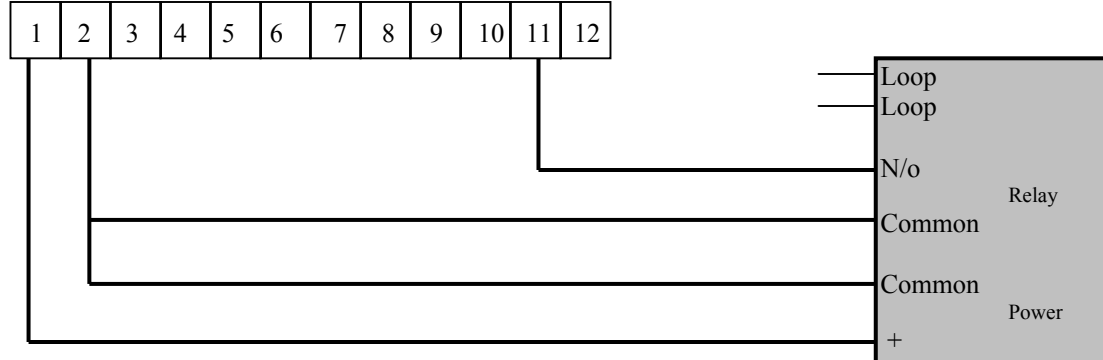

Siren Secondary Entrapment / Indicating Light For Gate Position

Light illuminates anytime gate is not closed (4 second delay)

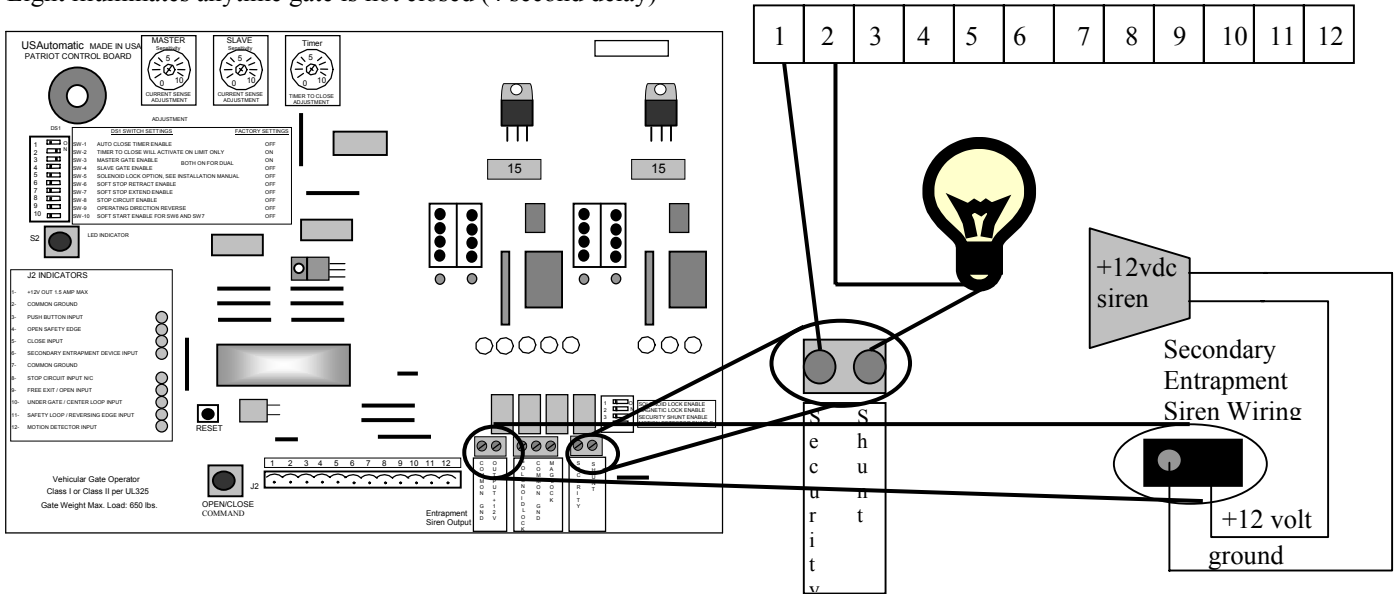

Security Shunt Circuit

This option allows the gate to be activated by a control device without activating the alarm. The alarm will activate if gate is forced. Security shunt relay will release 4 seconds after close limit.

Program function switch DS2 Switch #3 must be "ON" for Circuit to operate.
Leading edge of gate and fence Post shown using closed type Proximity switch.

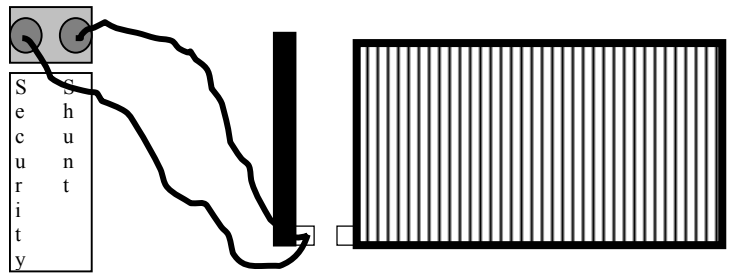

Magnetic Lock Wiring / Stone Lock or any 12 volt DC Solenoid Lock/Siren

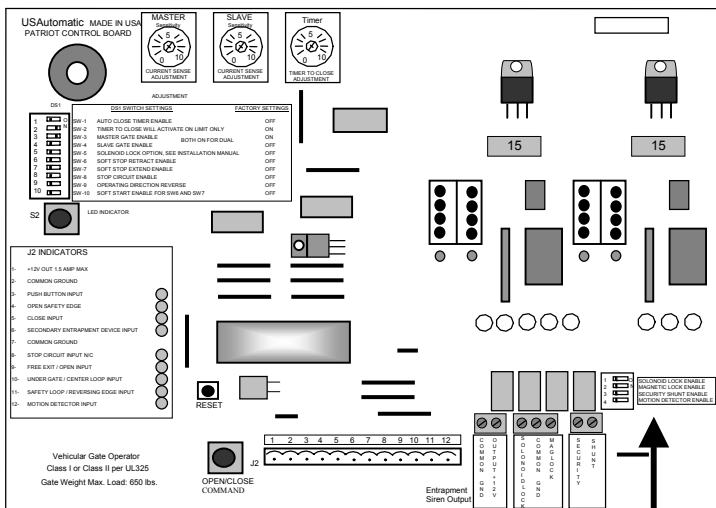

The Mag lock outputs +12vdc when the gate is on the closed limit. When the control board receives an open input the mag lock output goes to 0vdc .5 seconds before the gate begins to move.
The Solenoid / Siren output is +12vdc 1 second before the gate begins to open or close from a limit. The +12vdc output will remain until a limit is reached plus a 4 second delay. The control board will output the +12vdc 1 second before the gate begins to move and will output +12vdc for 4 seconds after the gate limit is reached. This also allows a siren or light to be operated prior to movement.
The output is regulated to 1.5 amps by a auto reset able fuse.

Magnetic lock and Solenoid lock outputs are labeled on the circuit board. Take care when running wires to avoid pinch areas.
NOTE: The corresponding DS2 switch must be turned on for the desired output to function. Both outputs can be used as long as the current draw does not exceed 1.5 amps.

Loops

Loop Position Diagram

Single Swing Gate with 2 Loops

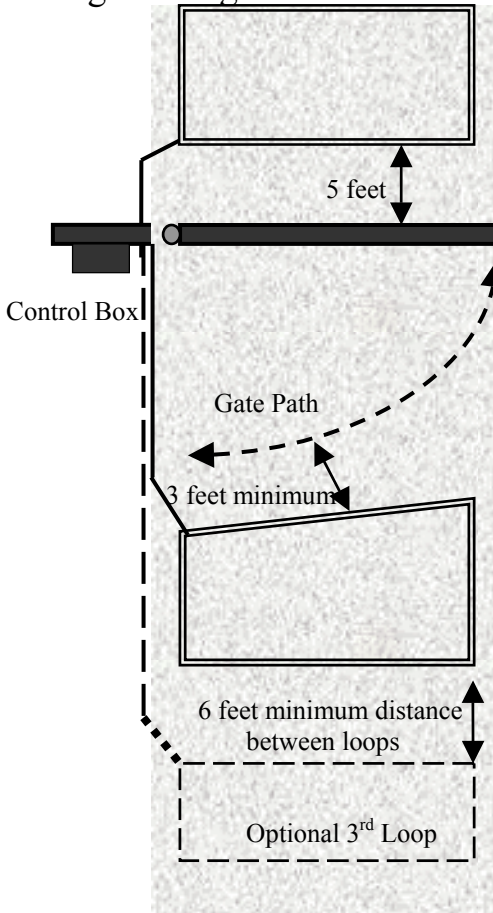

Dual Swing Gate with 2 Loops

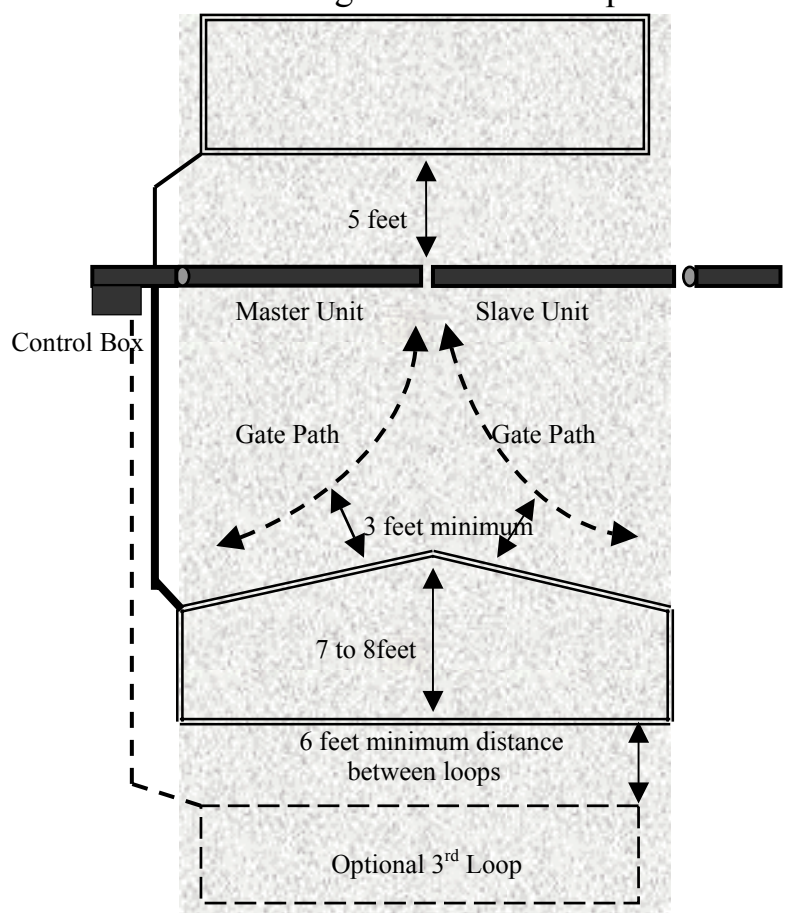

Center Loop

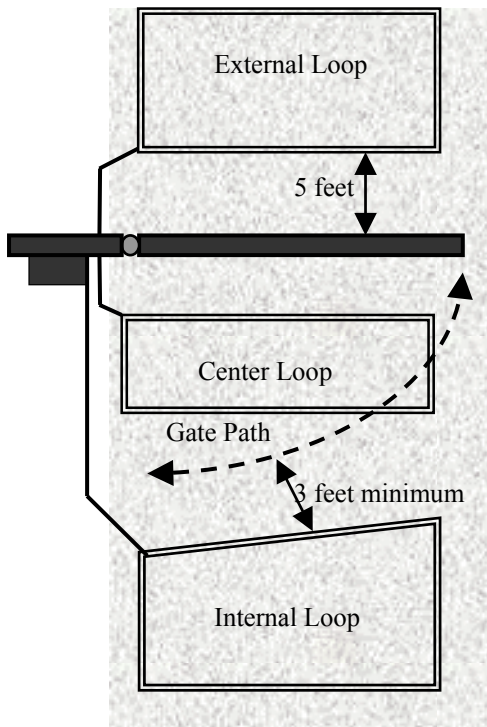

For larger gates, a loop can be placed directly under the gate, a separate detector is required. The loop will only be active when the gate is fully open and will ignore the signal at all other points. Consult a dealer or the factory for a complete explanation.

Loops

Typical Loop Saw cut

Top View

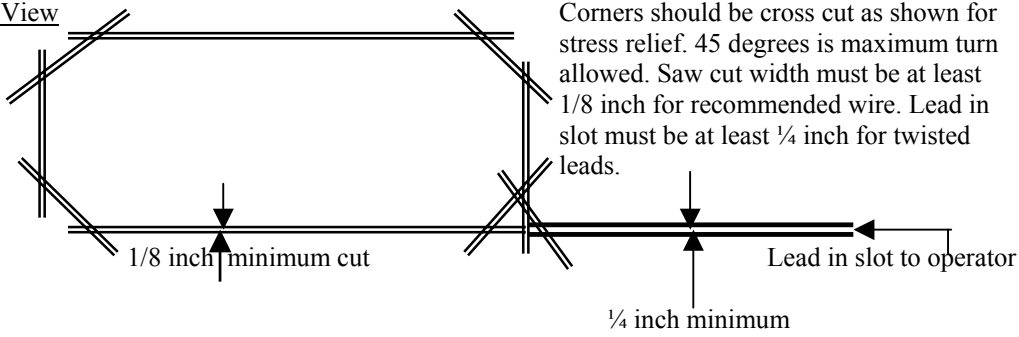

Side View

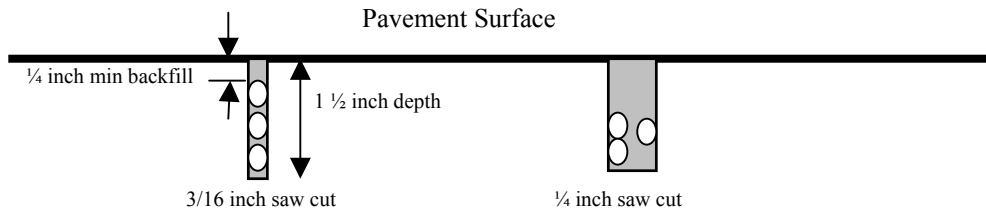

Proper wiring of two loops performing the same function.

Example: Inside and Outside Safety Loops

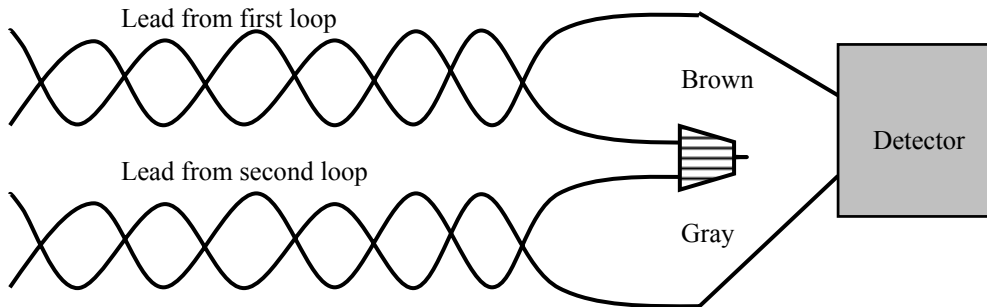

Loops

Loop Size Chart

The loop size is based on the width of the driveway. If the driveway is 14' wide, the loop would be a 6'x6', the minimum. This is determined by subtracting 4' off of each side of the drive, which would leave you 6'.

See chart below for number of turns per loop size, plus lead in.

The loop itself should contain between 90 & 125 feet of wire in the loop, plus lead in.

Drive Width	Loop Size	Number of Turns Per Foot		
		2	3	4
14 feet and under	6' X 6'			96'
16 feet	6' X 8'			112'
18'	6' X 10'		96'	
20'	6' X 12'		108'	
22'	6' X 14'		120'	
24'	6' X 16'		132'	
26'	6' X 18'	96'		
28'	6' X 20'	104'		
30'	6' X 22'	112'		
32'	6' X 24'	120'		

The location of the loop is also important. If a loop is located too close to the gate, it will detect the gate itself, giving false operation. If the loop is too far away from the gate a small vehicle might not be detected. Loops should be about 5' from the centerline of a gate when closed. See Loop Position on previous 2 pages.

Loops

Other Loop Detector Facts

1. Always clean saw cuts thoroughly with water, air or brush to remove all debris prior to installing wire.
2. Recommended loop wire is TFFN #16 gauge stranded wire. Available at electric supply distributors.
3. No splices are permitted in the loop or loop leads. One continuous wire should be used.
4. Lead wires should be twisted a minimum of 4 twists per foot to eliminate false sensing. Twists should begin at the edge of the loop and continue to detector.
5. Do not use metal or sharp objects to push the loop wire into the saw cut. The slightest nick or cut in the insulation will cause the loop to ground out and malfunction. To test for shorts, use a megohm meter or "Megger" between either loop lead and earth ground with both leads disconnected from the detector. The resistance should be greater than 50 megohms.
6. Use silicon caulk for backfill. Gray for concrete, black for asphalt. 25-Year life rating is preferred.
7. Never set adjacent loops on the same frequency. False activation will occur.
8. Some brands of detectors have an external or internal sensitivity adjustment. Usually the factory setting is sufficient if internal adjust type. Be very careful and use extreme caution when decreasing sensitivity.
9. Most false activations are caused by an improperly installed loop or a shorted loop. The loop should be tested and validity determined before adjusting sensitivity. See # 5 above.
10. Most detectors used in the gate business are fail-safe. This means that if the loop fails, the gate will be given a continuous signal. When power is disconnected from a detector, the signal output is also given.
11. ASB, or automatic sensitivity boost if available should be on if large truck or trailer traffic is likely.

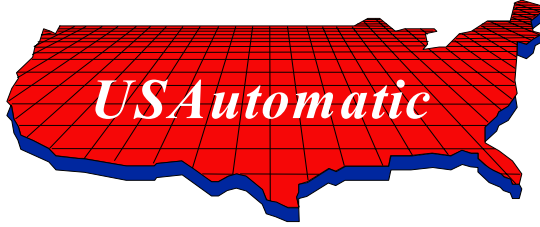

PATRIOT I
PATRIOT II
Limited 5 Year
Warranty

The PATRIOT Gate Operator is warranted to be free of defects in materials or workmanship for a period of 5 years from date of purchase on the electronic control board and 12 months on all other components. Any part, parts, or complete unit found to be defective within this period would, at the manufacturer's option be repaired or replaced at no charge if returned freight prepaid. New or factory rebuilt replacement parts are warranted for the remaining portion of the original warranty period. The manufacturer will pay for standard ground freight on the return of the repaired or replaced items under this warranty. The manufacturer will not be responsible for field service or labor charges incurred in the removal or replacement of defective parts. Furthermore, the manufacturer will not be responsible for incidental or consequential damages.

This warranty is in lieu of all other warranties expressed or implied and shall be considered void if damage was due to improper use or installation, connection to an improper power source, or if caused by fire, flood, lightning and other acts of nature, or by vehicles or vandalism.

This warranty gives you specific legal rights, and you may have other rights, which vary from state to state. Some states do not allow limitations or exclusions of implied warranties so these may not apply to you.

Keep this portion for your records

Model: _____ **Serial Number*:** _____

Date of Purchase: _____ **Purchased from:** _____

CUT HERE

<u>RETURN THIS PORTION TO:</u>	
USA Automatic 118 Hillside Drive Lewisville, Texas 75057 Toll Free 1-888-204-0174	
Model: _____	Date of Purchase: _____
Serial #: _____	Purchased from: _____
Name: _____	
Address: _____	
City: _____	State: _____ Zip: _____

- Serial number can be found by removing cover and looking on control board.